

# Paddle Type Flow Meter

# TSK

## Installation and Operating Instructions

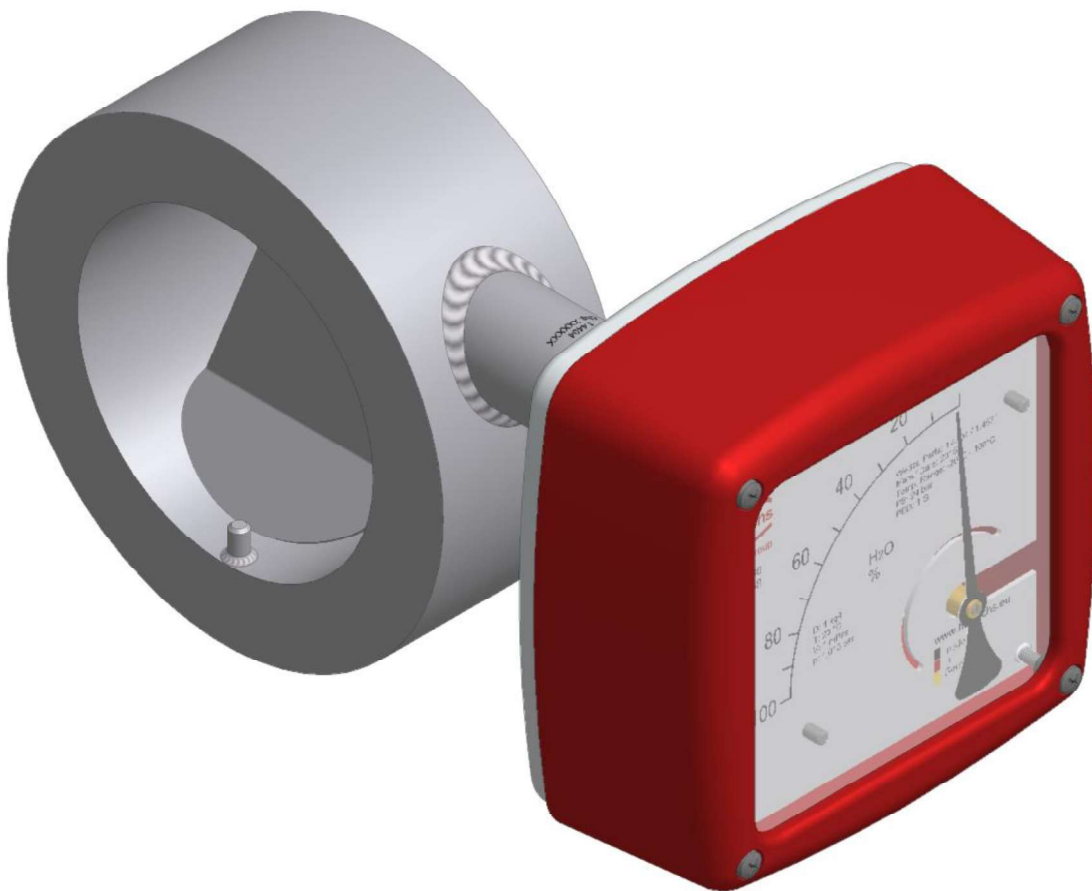

## Contents

<b>1</b>	<b>INTRODUCTION</b> .....	<b>4</b>
<b>2</b>	<b>IDENTIFICATION</b> .....	<b>4</b>
<b>2.1</b>	<b>Supplier/manufacturer</b> .....	<b>4</b>
<b>2.2</b>	<b>Product type</b> .....	<b>4</b>
<b>2.3</b>	<b>Product name</b> .....	<b>4</b>
<b>2.4</b>	<b>Issue date</b> .....	<b>4</b>
<b>2.5</b>	<b>Version no.</b> .....	<b>4</b>
<b>3</b>	<b>APPLICATIONS</b> .....	<b>4</b>
<b>4</b>	<b>SAFETY INSTRUCTIONS</b> .....	<b>4</b>
<b>4.1</b>	<b>Intended use</b> .....	<b>4</b>
<b>4.2</b>	<b>Installation, start-up and operating personnel</b> .....	<b>4</b>
<b>4.3</b>	<b>Packaging / Storage / Transportation</b> .....	<b>5</b>
<b>5</b>	<b>OPERATIONAL MODE AND SYSTEM DESIGN</b> .....	<b>5</b>
<b>5.1</b>	<b>Measuring principle</b> .....	<b>5</b>
<b>5.2</b>	<b>System design</b> .....	<b>5</b>
<b>6</b>	<b>INPUT</b> .....	<b>6</b>
<b>6.1</b>	<b>Measured variable</b> .....	<b>6</b>
<b>6.2</b>	<b>Measuring range (lower-range and upper-range value)</b> .....	<b>6</b>
<b>6.3</b>	<b>Measuring range table</b> .....	<b>6</b>
<b>7</b>	<b>OUTPUT SIGNALS</b> .....	<b>6</b>
<b>7.1</b>	<b>Binary output</b> .....	<b>6</b>
7.1.1	KEI1 or KEI2 limit switches.....	6
7.1.2	KEM1 or KEM2 limit switches (special version) .....	7
<b>7.2</b>	<b>Analog output with the ES magneto-electric transmitter</b> .....	<b>7</b>
<b>7.3</b>	<b>Typ ES-PPA and ES-FF</b> .....	<b>7</b>
<b>8</b>	<b>CHARACTERISTIC VALUES</b> .....	<b>7</b>
<b>8.1</b>	<b>Measuring Accuracy</b> .....	<b>7</b>
8.1.1	Reference conditions.....	7
8.1.2	Measured error.....	7
8.1.3	Repeatability .....	7
<b>8.2</b>	<b>Influence of ambient temperature</b> .....	<b>7</b>
<b>8.3</b>	<b>Influence of media temperature</b> .....	<b>7</b>
<b>9</b>	<b>CONDITIONS OF USE</b> .....	<b>7</b>
<b>9.1</b>	<b>Installation conditions</b> .....	<b>8</b>
9.1.1	Mounting/start-up .....	9
9.1.2	Device settings.....	10
9.1.3	Switchpoint adjustment on inductive limit switches KEI.....	10
9.1.4	Adjustment of KEM1 / KEM2 Microswitches .....	10
9.1.5	Operation in hazardous areas .....	11
<b>9.2</b>	<b>Ambient conditions</b> .....	<b>12</b>
9.2.1	Ambient temperature limits .....	12
9.2.2	Storage temperature .....	12
9.2.3	Climatic category.....	12
9.2.4	Degree of protection.....	12
9.2.5	Shock resistance/vibration resistance.....	12
9.2.6	Electromagnetic compatibility .....	13
<b>9.3</b>	<b>Fluid conditions</b> .....	<b>13</b>
9.3.1	Fluid temperature limits .....	13
9.3.2	Diagram: Max. ambient temperature based on fluid temperature for sensor ES.....	13
9.3.3	Media Pressure limit.....	13
9.3.4	Physical state.....	13
9.3.5	Density.....	13
9.3.6	Pressure loss .....	13
<b>10</b>	<b>DESIGN DETAILS</b> .....	<b>14</b>
<b>10.1</b>	<b>Type of construction / dimensions</b> .....	<b>14</b>
10.1.1	Indicator housing Aluminum .....	14
10.1.2	Indicator housing stainless steel .....	15
<b>10.2</b>	<b>Dimensions TSK-C, TSK-S, TSK H</b> .....	<b>17</b>

10.3	Weight .....	17
10.4	Sealing face.....	17
10.5	Materials .....	17
11	ELECTRICAL CONNECTION .....	18
11.1	Wiring diagram for ES transmitter .....	18
11.2	Wiring diagram for ES transmitter with 4-20 mA output and 2 limit transducers .....	19
11.3	Wiring diagram for ES transmitter with 4- 20 mA output, pulse output and limit switches .....	19
11.4	Wiring diagram for inductive limit switches SJ-3,5 N.....	20
11.5	Wiring diagram for KEM 1 and KEM 2 micro switches .....	20
11.6	Devices with unconnected cable end .....	20
12	POWER SUPPLY .....	21
13	CE MARK.....	21
14	ORDER INFORMATION .....	21
14.1	Available accessories.....	21
15	STANDARDS AND DIRECTIVES, CERTIFICATES AND APPROVALS .....	21
16	MAINTENANCE .....	21
17	TROUBLE SHOOTING.....	21
18	RETURNING DEVICES FOR REPAIR AND SERVICE .....	22
19	SPARE PARTS .....	22
20	EXPLOSION DRAWINGS .....	22
20.1	Indicator unit.....	22
20.1.1	Complete Indicator unit with local scale.....	23
20.1.2	Complete indicator unit, c/w 1 pc limit switch KEI (SJ 3,5-N) .....	23
20.1.3	Complete Indicator unit with 2 pcs limit switch KEI (SJ 3,5-N).....	23
20.1.4	Complete indicator unit with 2 pcs SPDT micro switch KEM .....	23
20.1.5	Complete indicator unit with 1 pc SPDT micro switch KEM.....	24
20.1.6	Complete indicator with transmitter ES Ex HART .....	24
21	MODEL CODE .....	24
22	DECONTAMINATION CERTIFICATE FOR DEVICE CLEANING.....	27
23	DECLARATION OF CONFORMITY .....	28

## 1 Introduction

These Installation and Operating Instructions serve as a tool for the correct installation, operation and maintenance of the device. They are a supplement to the TSK Device Description. Read the manual carefully before the device is installed and put into use. It does not include special versions or applications.

**All devices are thoroughly checked for order compliance and operability before delivery.**

**Upon receipt, please conduct a visual inspection of possible damage that may be identified as having occurred during shipment.** If you discover any defect, please contact our head office in Cologne or the responsible local sales office. Apart from a description of the error, we will need the equipment type and serial number of the delivery.

Heinrichs Messtechnik shall not furnish guarantee for any repair work done without prior notice. Unless otherwise agreed on, the rejected parts must be made available to us in case a claim is made.

## 2 Identification

### 2.1 Supplier/manufacturer

Heinrichs Messtechnik GmbH  
Robert-Perthel-Str. 9 · D-50739 Köln  
Phone +49 (221) 49708 - 0  
Fax +49 (221) 49708 - 178  
Internet: <http://www.heinrichs.eu/>  
E-mail: <mailto:info@heinrichs.eu>

Instruments series TSK will be delivered without label stickers. All important informations such as:  
-Measuring range  
-Manufacturer  
-Serial number  
-Model code  
-CE marking  
-Necessary Ex marking  
are printed on instrument scale and can be read from there.



### 2.2 Product type

Paddle-type flow meter in all-metal design

### 2.3 Product name

#### TSK with subgroups

TSK-C (carbon steel)  
TSK-S (stainless steel)  
TSK-H (Hastelloy)  
TSK-K (Polypropylene/stainless steel)  
TSK-S (stainless steel)  
TSK-J (Polypropylene/Hastelloy)  
TSK-P (PTFE/Hastelloy)

### 2.4 Issue date

17.01.2021

### 2.5 Version no.

File: TSK\_BA\_21.01\_en.doc

## 3 Applications

The TSK meter is suitable for flow measurement of liquid and gaseous products in pipes. **The special advantage is that it can be used for all directions of flow.** It shows the current flow rate in volume or mass per unit in time.

Applications: flow measurement, monitoring, adjusting and control of liquid and gaseous products. The meter's design makes it ideal for processes under difficult and adverse operating conditions. The devices are available with additional electrical equipment for process monitoring and control.

## 4 Safety instructions

### 4.1 Intended use



The TSK paddle-type flowmeter may be used only for flow measurements of liquid and gaseous media. The manufacturer shall not be liable for damages that may result from improper or unintended use. When dealing with an aggressive medium, clarify the material durability of all wetted parts. When using the device in hazardous areas, follow the applicable national installation rules.

### 4.2 Installation, start-up and operating personnel



Only trained specialists authorized from the system operator may carry out the installation, electrical installations, startup, maintenance and operation. They must read and understand the operating manual and follow its instructions.

Basically, follow the conditions and provisions applicable in your country.

### 4.3 Packaging / Storage / Transportation

Carefully unpack the device to avoid damage.

The operability of the paddle can be tested by pressing it in the direction of flow. The pointer position of the indicator mechanism must follow the direction of movement. The torsion spring resets the paddle back to zero positions after release.

With the help of the delivery note enclosed in the packaging, check whether all technically relevant data correspond with your requirements.

Storage and installation must be done in a clean and dry room so that contamination – especially of the interior of the fitting – is avoided. Follow the limit values for ambient temperature. When transporting the device to a remote mounting location, we recommend that you reuse the factory-issued packaging and the transport protection.

## 5 Operational mode and system design

### 5.1 Measuring principle

If a medium flows with sufficient velocity through the horizontally or vertically arranged **measuring chamber (1)** of the TSK fitting, the **paddle (2)** will swivel around the axle until the force of the medium and the opposing force of the paddle surface plus the spring tension establish equilibrium. The angular position or the position of equilibrium of the **paddle (2)** in the **measuring chamber (1)** is the measure for the flow. The encapsulated ring-type **permanent magnet (4)** at the end of the **paddle axis (3)** then transmits this position to the **scale (6)** and the optional electronic evaluators through the magnet tracking **indicator (5)** system. This happens safely and without packing glands.

The flow rates shown on the scale only apply to the calibrated medium or to a medium with the same physical characteristics.

### 5.2 System design

The TSK flow meter mainly consists of the fitting with the measuring chamber, the measuring elements "torsion spring" and "paddle," the magnet tracking indicator system and the indicator unit.

The flow meter is manufactured as a sandwich-type construction and available for the nominal sizes from DN 25(1") to DN 500(20").

- 1 Fitting
- 2 Paddle
- 3 Paddle axis with torsion spring
- 4 Ring-type permanent magnet
- 5 Magnet tracking indicator system
- 6 Scale
- 7 Cover with window
- 8 Base plate of indicator housing
- 9 Coupling chamber
- 10 socket with bearing unit

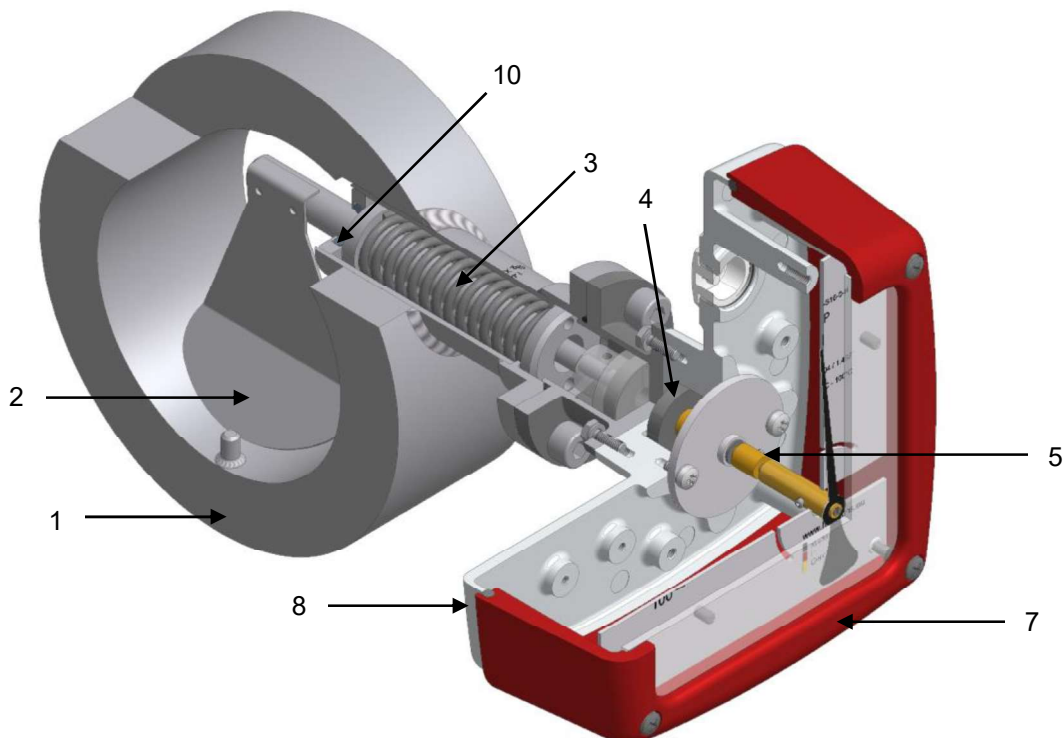

## 6 Input

### 6.1 Measured variable

Volume flow

### 6.2 Measuring range (lower-range and upper-range value)

Measuring range span	15 – 100%
Smallest measuring range	0.5 – 3.5 m <sup>3</sup> /h water
Largest measuring range	200 – 1500 m <sup>3</sup> /h water
Electrical signal outputs	20 – 100%

### 6.3 Measuring range table

Nominal size DN / Inch	Measuring Range	Measuring range for water 1000 kg/m <sup>3</sup> at 20°C		Pressure loss (mbar)
25* / 1"	A1	0,5 – 3,5	m <sup>3</sup> /h	
40* / 1 1/2"	B1	1,5 - 6	m <sup>3</sup> /h	
	B2	1,5 - 10	m <sup>3</sup> /h	
	B3	3 - 15	m <sup>3</sup> /h	
50 / 2"	C1	1,5 – 10	m <sup>3</sup> /h	120
	C2	3 – 30	m <sup>3</sup> /h	50
65 / 2 1/2"	D1	1,5 – 14	m <sup>3</sup> /h	40
	D2	4 – 30	m <sup>3</sup> /h	60
	D3	6 - 50	m <sup>3</sup> /h	60
80 / 3"	E1	4 – 24	m <sup>3</sup> /h	40
	E2	10 – 60	m <sup>3</sup> /h	60
100 / 4"	F1	6 – 40	m <sup>3</sup> /h	40
	F2	8 – 80	m <sup>3</sup> /h	60
125 / 5"	G1	10 - 60	m <sup>3</sup> /h	40
	G2	20 - 120	m <sup>3</sup> /h	60
150 / 6"	H1	15 - 100	m <sup>3</sup> /h	35
	H2	30 - 200	m <sup>3</sup> /h	55
200 / 8"	J1	25 - 160	m <sup>3</sup> /h	35
	J2	50 – 275	m <sup>3</sup> /h	45
	J3	60 - 400	m <sup>3</sup> /h	55
250 / 10"	K1	50 - 300	m <sup>3</sup> /h	30
	K2	75 - 400	m <sup>3</sup> /h	40
	K3	80 - 500	m <sup>3</sup> /h	40
300 / 12"	L1	80 - 400	m <sup>3</sup> /h	30
	L2	100 - 600	m <sup>3</sup> /h	40
350 / 14"	M1	120 - 700	m <sup>3</sup> /h	30
	M2	150 - 1000	m <sup>3</sup> /h	40
400 / 16"	N1	150 - 800	m <sup>3</sup> /h	30
	N2	200 - 1300	m <sup>3</sup> /h	40
500 / 20"	P1	200 - 1300	m <sup>3</sup> /h	40
	P2	200 - 1500	m <sup>3</sup> /h	40

\* Full scale value on instruments with stainless steel sealing will be 15% lower

## 7 Output Signals

### 7.1 Binary output

By using the segment discs (double or single adjustable) of the slot-type switches or the eccentric discs for micro switches, any switching point between 20% and 90% of the flow rate can be set.

#### 7.1.1 KEI1 or KEI2 limit switches

KEI 1 inductive limit switch

KEI 2 inductive limit switch

Standard slot sensor type SJ 3,5 N (BO), made by Pepperl+Fuchs  
(special switch possible, e.g. SN version)

Safety class: PTB Nr. 99 ATEX 2219 X

PTB Nr. 00 ATEX 2048 X

TSK flow meters can be equipped with max. 2 pcs. limit switch.

### 7.1.2 KEM1 or KEM2 limit switches (special version)

Switches are SPDT micro switches which are activated by a cam disk.  
 KEM 1 = 1 SPDT micro switch  
 KEM 2 = 2 SPDT micro switches

#### Maximum switching capacity:

230 VAC 50/60Hz	6 A
24 VDC	0.5 A
110 VDC	0.2 A

The switching points are usually factory preset. The procedure for individual contact adjustments see section 9.1.4.

## 7.2 Analog output with the ES magneto-electric transmitter

The electric transmitter ES is factory-calibrated to the scale values upon shipment. The signal output is supplied exclusively in a two-wire connection at 4-20 mA. The 4-20 mA signal has the HART® protocol - alternatively Profibus PA® or Foundation Fieldbus® interface - see Point 7.3

**Additional options:** 2 limit switches, alternatively 1 limit switch and 1 pulse output

The signal output and the limit values can be configured using a HART® modem operating on the following configuration programs: PDM from Siemens or AMS from Rosemount. Furthermore, a HART® hand-held terminal (with DD software) can also be used. For more information about configuration, please refer to the separate Operating Instructions for the ES.

**Safety class:** DMT 00 ATEX 075 / II2G Ex ia IIC T6



**When installing electrical equipment in hazardous areas, the conditions and provisions specified in the approval documents must be followed.**

## 7.3 Typ ES-PPA and ES-FF

Series ES-PPA and ES-FF transmitters are FISCO field devices that are connected via a two-wire field bus circuit according to the FISCO model.

The devices can also be connected to intrinsically safe field bus circuits which do not correspond to the FISCO model. In this case the electrical maximum values (Ui, Ii, Pi, Li and Ci) must be observed.

For application details see the separate "Manual for hazardous locations".

# 8 Characteristic values

## 8.1 Measuring Accuracy

### 8.1.1 Reference conditions

Water 20°C

### 8.1.2 Measured error

± 2,5 % of full scale for local display  
 ±0.2% additional error for electronic transmitter ES

### 8.1.3 Repeatability

±0.8% of full scale

## 8.2 Influence of ambient temperature

- |   |   |
|---|---|
| 1. Without electrical equipment and with limit transducer | without influence                       |
| 2. With ES transmitter:                                   | ±0.5% / 10 K reference temperature 20°C |

## 8.3 Influence of media temperature

Deviations in fluid temperature from the temperature observed during calibration can result in a proportional display fault because of the corresponding change in density. Changes in viscosity cause a non-linear display fault.

# 9 Conditions of use

The VDI/VDE guidelines 3513, Sheet 3, must be observed. The meter is suitable for:

- 1) Liquids with sufficient flow ability which are free of solids, do not bond and do not tend to settle.
- 2) Gases with laminar / linear flow performance and sufficient inlet pressure

For paddle-type meters, viscosity does not need to be considered physically as it generally does not significantly influence the measuring result.

## 9.1 Installation conditions

The measuring device can be installed vertically or horizontally (according to the direction of flow indicated in the order). The nominal size of the product line to be connected must correspond to the nominal size of the measuring device. The best installation position is between loose flanges. When installing the device between weld-on flanges, the flange hole pattern has to be turned so that the indicator unit is in a horizontal position if the pipe arrangement is horizontal.

**The nominal size of the process pipe to be connected must correspond to the nominal size of the device. Avoid fittings or any installation which will reduce the nominal pipe diameter at the inlet of the instrument.**



Please consider a sufficient and necessary distance to magnet influencing parts like solenoid valves or ferromagnetic parts e.g. carbon steel panels/girder. We recommend that the lateral distance between two adjacently mounted devices to be **300 mm**. The devices can be mounted close together if vertically offset by one device length. The minimum lateral distance for interfering steel parts should be **200 mm**. In case of doubt, check the interference by moving the device back and forth in the selected distance by about 200 mm and testing whether the pointer position changes.



At the place of installation the limit values for temperature and humidity must be observed. Corrosive atmosphere must be avoided. Should that be possible arrange for a sufficient ventilation.

Select the mounting location so as to enable a reliable reading of the scale values.



**During installation, the standard inlet section must be 5 x D and the standard outlet section 3 x D. On very un-linear flow profiles e.g. through regulating valves, shut-off valves etc. the inlet straight is recommended to be doubled.**

Please take note as well of the space requirement for a possible disassembly of the device.

### Installation examples with respect to the directions of flow:

horizontal; from the left to the right

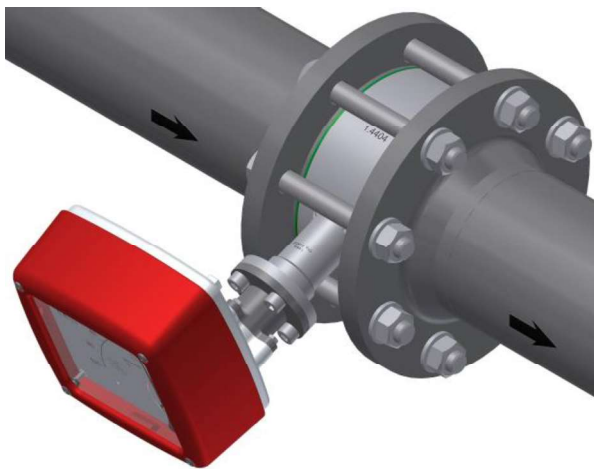

horizontal; from the right to the left

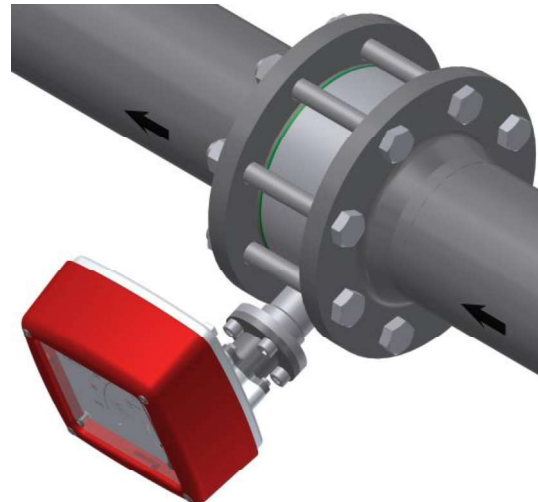

vertical: flow from top to the bottom

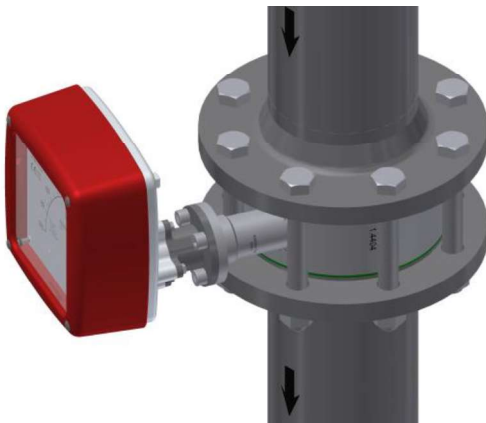

vertical: flow from bottom to the top

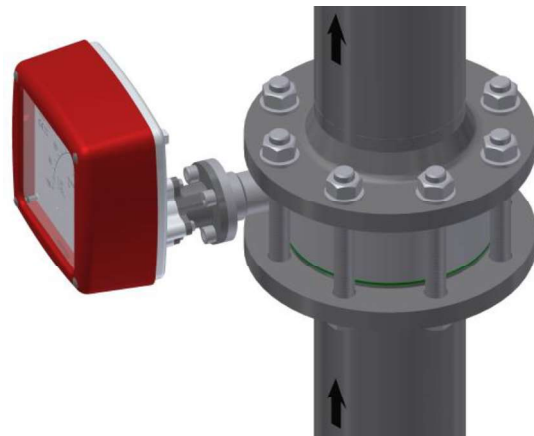

**Caution:**

When mounting the device in the horizontal position, make sure the indicator unit is not pointing upwards. This is to prevent water lodging on the glass window and entering the device under the protective collar of the housing.

**9.1.1 Mounting/start-up**

Before installation, check whether the measuring element is free from foreign bodies. The instrument must be mounted perpendicularly or horizontally according the planned and confirmed direction of flow.

The nominal size of the device and that of the pipes must be the same. The pressure stages and, hence, the dimensions of the flanges must correspond. The surface roughness of the flange sealing surface must be suitable for the prescribed gaskets.

Check whether the mounting clearance between the flanges of the pipes corresponds to the assembly dimension of the device plus two gaskets. To achieve stress-free mounting, the flanges of the pipes must be aligned parallel to each other.

Process pipe should be slowly flushed to avoid a surge of gas bubbles. Basically, avoid activation using solenoid valves.

Use connecting bolts and gaskets in the prescribed dimensions. The gaskets must be suitable for the operating pressure, the temperature and the measured medium. With PTFE- and PP coated devices, use gaskets whose interior and exterior diameter correspond to the sealing strip of the device.

Tighten the flange bolts crosswise so that the process connections are tight. Pay particular attention to the tightening torques of screws, especially with PTFE- and PP-coated devices. The maximum torques are:

Nominal size	Nominal pressure	Tightening torques
DN25 / 1" ANSI	PN16	25 Nm
DN40 / 1 1/2" ANSI	PN16	35 Nm
DN50 / 2" ANSI	PN16	45 Nm
DN65 / 2 1/2" ANSI	PN16	46 Nm
DN80 / 3" ANSI	PN16	48 Nm
DN100 / 4" ANSI	PN16	50 Nm
DN125 / 5" ANSI	PN10	80 Nm
DN150 / 6" ANSI	PN10	90 Nm
DN200 / 8" ANSI	PN10	115 Nm
DN250 / 10" ANSI	PN6	95 Nm
DN300 / 12" ANSI	PN6	115 Nm
DN350 / 14" ANSI	PN6	140 Nm
DN400 / 16" ANSI	PN6	155 Nm
DN500 / 18" ANSI	PN6	160 Nm

(following VDI/VDE Guideline 3513)

Please check whether the pipe is adequately stable so that vibration or swinging of the device is out of the question. (Do not use steel mounting parts directly on the device.)

**9.1.2 Device settings**

The measuring equipment is delivered ready for operation according to your order specifications. **The limit switches** are set to the desired values. If you have submitted no requirements, the basic setting for

- 1 switch: **Minimum contact switching point at 20% of descending flow (damped/closed-circuit principle).**
- 2 switches: **Minimum contact switching point at 20% of descending flow and maximum contact switching point at 90% of ascending flow.**

**9.1.3 Switchpoint adjustment on inductive limit switches KEI**

The inductive contact can be adjusted via a limit switch indicator (2) located at the front side of the scale

- 1) unscrew 4 screws of the front cover and lift off the cover
- 2) **!! do not remove the scale !!**
- 3) unfasten 2 locking screws (3) of the red limit switch indicator (2)
- 4) move the red switch indicator (2) to the desired switch point on the scale and tighten the locking screws (3) again
- 5) mount the cover and tighten it's four screws again

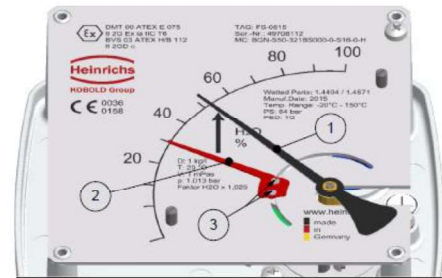

- 1 Pointer
- 2 Limit switch indicator (fig. MIN)
- 3 Limit switch indicator locking screws
- 4 Locking screw switching disc
- 5 Switching disc

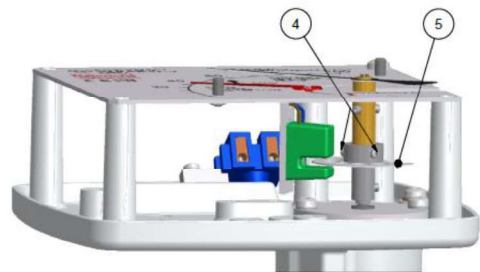

**9.1.4 Adjustment of KEM1 / KEM2 Microswitches**

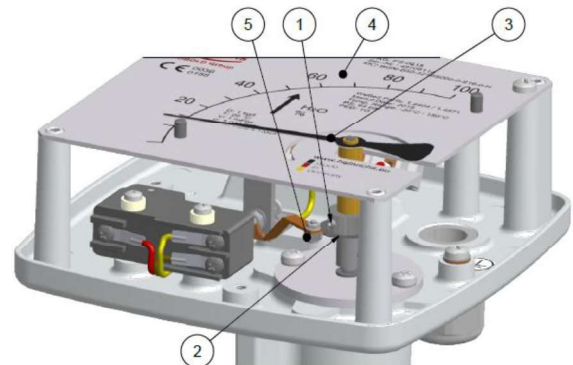
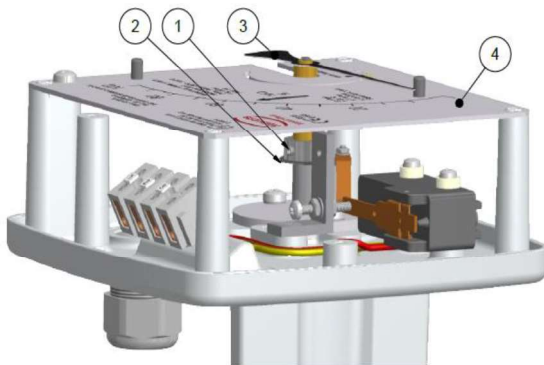

- 1 Locking screws switching disc
- 2 Switching disc
- 3 Pointer
- 4 Scale
- 5 Switching lever



**The KEM 1 / KEM 2 limit contacts do not have contact position indicators. The contact(s) are normally factory adjusted.**

- 1) Ensure that the supply lines are powerless and will not be switched active during operation.
- 2) unscrew 4 screws of the front cover and remove the cover
- 3) **!! do not remove the scale (4) !!**
- 4) Move the **pointer (3)** carefully in direction of the desired switch point
- 5) Unfasten the **screws (1)** of the **disc (2)** carefully and move the disc towards the lever of the micro switch
- 6) Depending on the switching function ( N/O or N/C ) the switch must be activated (for N/C ) or non activated (for N/O )

**Please consider switching hysteresis.**

### 9.1.5 Operation in hazardous areas

Only devices with Ex-marking may also be operated in hazardous areas.



Ambient-Temp.	Process-Temp.	Marking	Z o n e	Description
-40°C .. +65 °C	-25°C .. +150 °C	II 2G Ex h IIC T6...T3 Gb II 2D Ex h IIIC T85°C...T200°C Db	1	With switch
-40°C .. +70 °C	-25°C .. +200 °C	II 2G Ex h IIC T6...T3 Gb II 2D Ex h IIIC T85°C...T200°C Db	1	With ES
-40°C .. +80 °C	-40°C .. +350 °C	II 2G Ex h IIC T6...T1 Gb II 2D Ex h IIIC T85°C...T350°C Db	1	with purely mechanical device

#### 9.1.5.1 Without electrical equipment

The basic version of the flow meter is a *non-electrical device* without its own ignition sources and meets DIN EN 13463-1 requirements. It can be used in hazardous areas that require Category 2 equipment.

Marking:

 II 2G Ex h IIC T6...T2 Gb  
II 2D Ex h IIIC 80°C...T295°C  
Db  
Reg. Nr.: BVS 03 ATEX H/B 112  
Tech. File Ref. 03-02 X

Since the device does not have its own power sources that would result in a temperature increase, the fluid temperature is decisive for the maximum surface temperature.



When used in potentially explosive dust atmospheres, the device must be cleaned regularly in order to avoid deposits exceeding **5 mm**.

#### 9.1.5.2 With built-in electrical limit transducers

When the limit transducers are installed, the device becomes an electrical assembly and receives a marking in accordance with DIN EN 60079 from the entire device with the built-in electrical limit transducers.

The electrical and thermal data and the special conditions of the EC Type Examination Certificate of the built-in limit transducers must be observed (see also the diagram in Section 7.3.1).



The influence of the fluid temperature on the built-in signal transmitter must be observed. The over temperature of the maximum media temperature based on the maximum ambient temperature must be considered with a factor of **0.25**.

#### Example for built-in limit transducer:

Max. ambient temperature  $T_{amb} = 40^{\circ}\text{C}$   
 Max. fluid temperature  $T_m = 120^{\circ}\text{C}$   
 Factor for brought-in heat  $F = 0.25$   
 Temperature class T4

$T_{\ddot{u}}$  = Over temperature  
 $T_a$  = Ambient temperature of  
 limit transducer

$$T_{\ddot{u}} = T_m - T_{amb} = 120^{\circ}\text{C} - 40^{\circ}\text{C} = 80^{\circ}\text{C}$$

$$T_a = T_{\ddot{u}} * F + T_{amb} = 80^{\circ}\text{C} * 0,25 + 40^{\circ}\text{C} = 60^{\circ}\text{C}$$

In accordance with the tables in the PTB 99 ATEX 2219 X EC Type Examination Certificate, the SJ 3,5-... N... inductive sensor must be operated in the T5 temperature class with an intrinsically safe circuit that does not exceed the maximum values of the Type 3 circuit.

When using the device in hazardous areas, follow the applicable national installation rules.

#### Example for calculating the max. fluid temperature based on the max. ambient temperature for the built-in sensor Type ES.

$T_a = 70^{\circ}\text{C}$   $T_{amb} = 60^{\circ}\text{C}$   $F = 0.25$

$$T_m = \left( \frac{T_a - T_{amb}}{F} \right) + T_{amb} = \left( \frac{70^{\circ}\text{C} - 60^{\circ}\text{C}}{0,25} \right) + 60^{\circ}\text{C} = 100^{\circ}\text{C}$$

#### 9.1.5.2.1 Marking for built in limit switch SJ3,5...N...

The installed limit transducer of the company Pepperl & Fuchs is certified for the use in a explosive **gas** environment by PTB 99 ATEX 2219 X EC Type Examination Certificate and for the use in a explosive **dust** environment by **ZELM 03 ATEX 0128 X** EC Type Examination Certificate. The electrical and thermal data and the special conditions of these EC Type Examination Certificates must be observed.



PTB 99 ATEX 2219 X  
II 2G Ex ia IIC T6-T4  
ZELM 03 ATEX 0128 X  
II 1D Ex iaD 20 T108°C

#### 9.1.5.2.2 Marking with built in electrical transmitter ES



DMT 00 ATEX 075  
II2G Ex ia IIC T6

#### 9.1.5.3 Atmospheric conditions

In accordance with EN 1127, a "potentially explosive atmosphere" is defined as a mixture of air and combustible gases, vapour, mist or dust under atmospheric conditions. Such conditions are defined in EN 13463-1, para. 1, with values  $T_{atm} = -20\text{ °C}$  to  $+60\text{ °C}$  and  $P_{atm} = 0.8$  to  $1.1$  bar. Outside this range, safety parameters for most ignition sources are not available.

Usually, paddle-type flow meters operate under operating conditions outside the atmospheric conditions of 0.8 to 1.1 bar. Irrespective of the zone classification –safety parameters of explosion protection – are basically not applicable to the inside of the measuring tube.



**The operation with combustible products** is only allowed if a potentially explosive air mixture is not formed inside the flow meter. Where this condition is not met, the operator will need to assess the ignition hazard in each individual case and give due consideration to existing parameters (e.g. pressure, temperature, process product, materials of construction for the measuring tube).

#### 9.1.5.4 Ground connection

On paddle type flow meters - in principal it is possible - that through the flow of non-conductive liquids a charge separation occur inside the fitting. A dissipation of such charge carriers from the metal flow fitting through earthing must be ensured.

For that reason, paddle type flow meters must be permanently grounded by the operator by way of the process connections (flanges) in order to discharge electrostatic build-up. The operator is also responsible for extending the ground continuity of the process pipeline.

If grounding cannot be made via the process connections (plastic process connections or undefined connections), the flow meter must be connected to the local ground potential via the flanges. This connection only ensures electrostatic grounding of the device and does not meet the requirements for equipotential bonding.

## 9.2 Ambient conditions

### 9.2.1 Ambient temperature limits

**Without electrical accessories:**

-40°C to +80°C

**With limit transducer:**

-40 °C to +65°C

**With ES signal transmitter:**

-40°C to +70°C

**For the hazardous area version, take note of the maximum ambient temperatures depending on the temperature class as specified in the Type Examination Certificate.**

### 9.2.2 Storage temperature

The storage temperatures are identical to the ambient temperature ranges.

### 9.2.3 Climatic category

Weather-protected and/or unheated locations,  
Class C according to IEC 654 Part 1

### 9.2.4 Degree of protection

IP 65 (Aluminum indicator unit)  
IP 67 (Stainless steel indicator unit)

### 9.2.5 Shock resistance/vibration resistance

The meter should be protected from extreme shocks and vibrations, which could cause damage.

## 9.2.6 Electromagnetic compatibility

EN 61000-6-2:2011 Immunity industrial environment  
 EN 61000-6-3:2011 Emitted interference residential environment  
 EN 55011:2011 Group 1, Class B, ISM ratio-frequency equipment  
 EN 61326-1:2013 EMC requirements –  
 NAMUR recommendation NE 21

## 9.3 Fluid conditions

### 9.3.1 Fluid temperature limits

TSK-C/S/H -40°C to 200°C  
 TSK-K/J 0°C to 80°C  
 TSK-P -20°C to 125°C

A displaced indicator unit is necessary if the fluid temperature falls short of 0°C or rises above 200°C.

The effect of the fluid temperature on the indicator unit and its built-in components must be considered.

### 9.3.2 Diagram: Max. ambient temperature based on fluid temperature for sensor ES

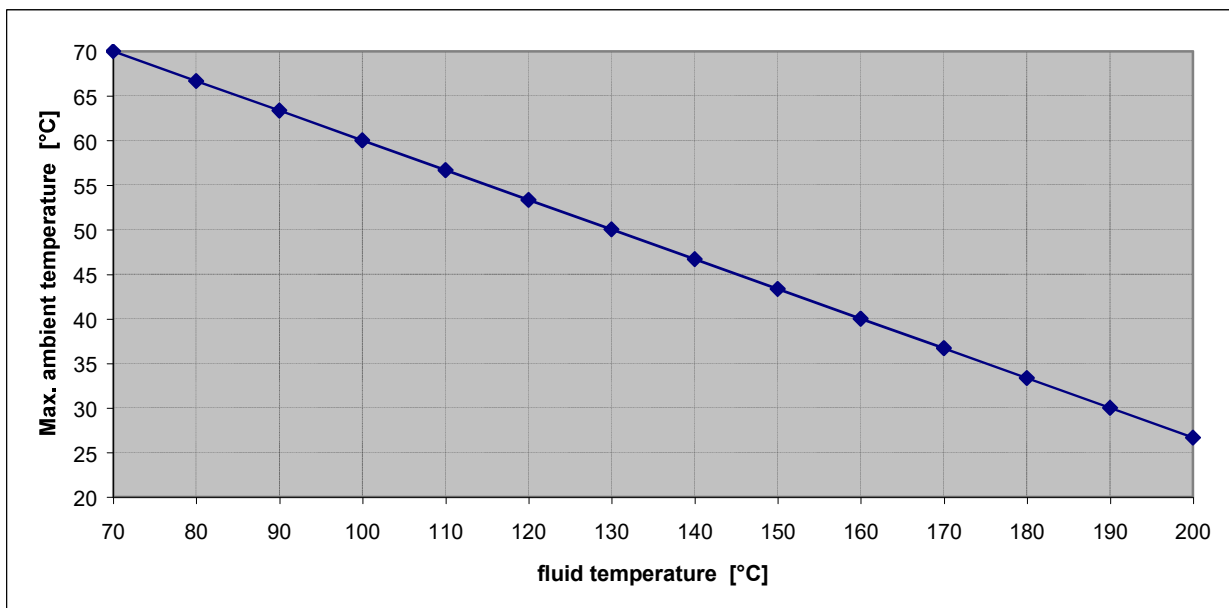

### 9.3.3 Media Pressure limit

#### TSK-C

DN 150/200/250 PN16  
 DN 250 and above PN10

#### TSK-S/TSK-H

DN 25/50/80 PN40  
 DN 100/125/150/200/250 PN16  
 DN 300 and above PN10

#### TSK-K / TSK-P / TSK-J

DN 25/40/50/65/80/100 PN16  
 DN 125/150/200 PN10  
 DN 250 and above PN6

### 9.3.4 Physical state

Liquid or gaseous

### 9.3.5 Density

Liquids: up to 2.0 kg/l

### 9.3.6 Pressure loss

Pressure loss: Depends on the instrument size and the measuring range (see measuring range table 6.3).

## 10 Design details

The measuring device consists of a sandwich-type fitting (mounting length 64 mm), which can be installed between flanges. The fitting contains the paddle with the resetting spring. The paddle is mounted on an axis that has a permanent magnet at the end. The torsion caused by the paddle will be transmitted by the axis magnet to the counter magnet system and operate the indicator unit.

### 10.1 Type of construction / dimensions

#### 10.1.1 Indicator housing Aluminum

(missing dimensions see table 11.2)

horizontal flow from left to right

NOTE: "Indicator on distance =  $L + 100$  mm"

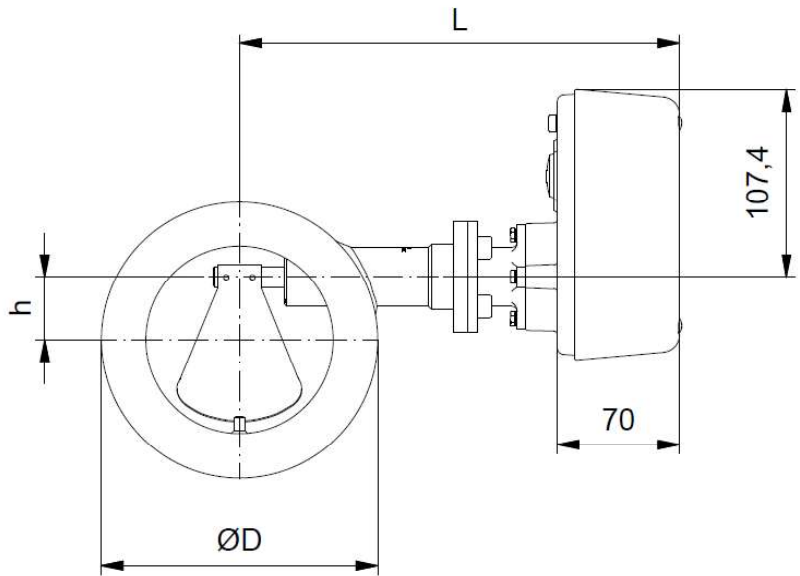
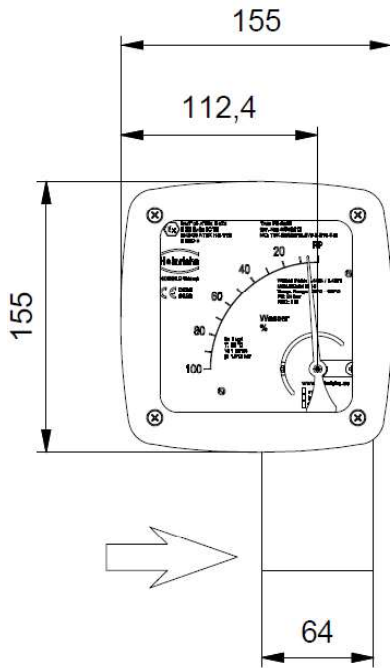

Horizontal flow from right to left

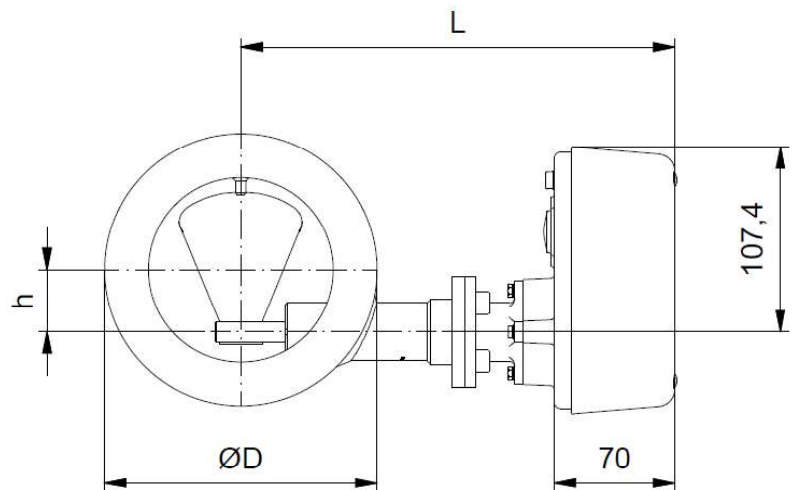
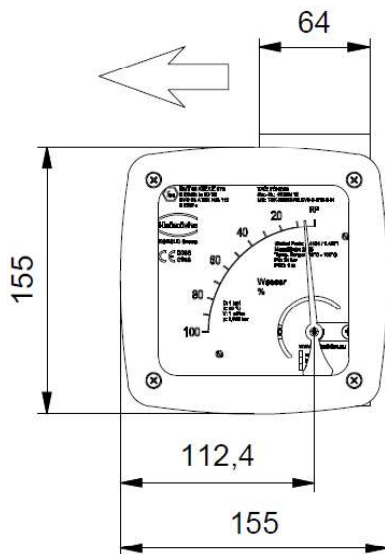

Vertical flow from top to bottom

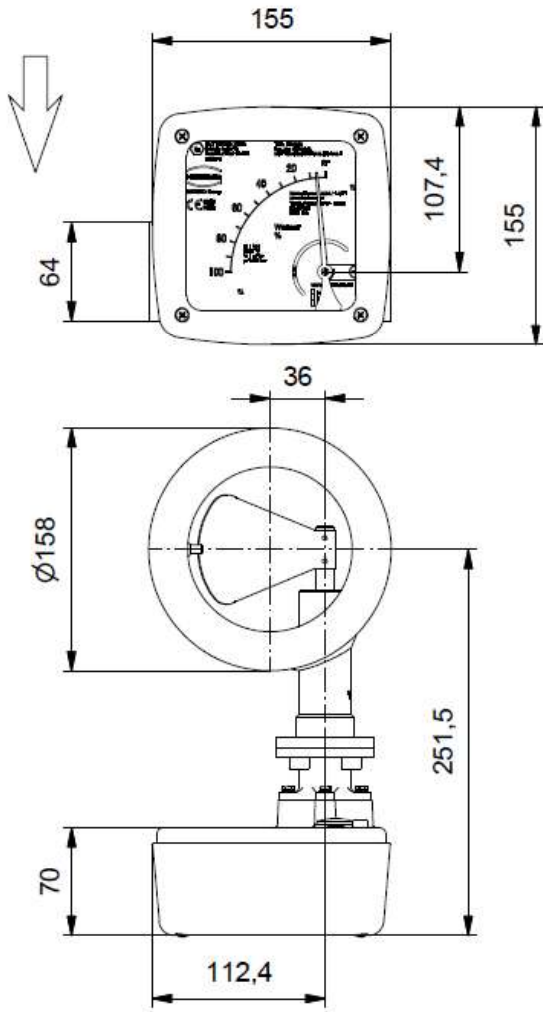

Vertical flow from bottom to top

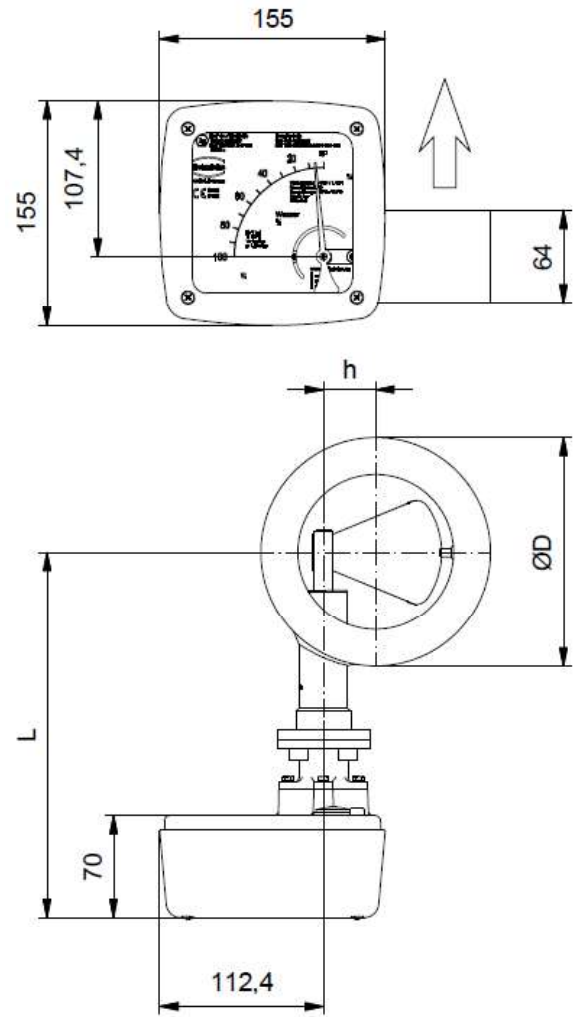

10.1.2 Indicator housing stainless steel

Horizontal flow from left to right

"Indicator on distance =  $L + 100$  mm"

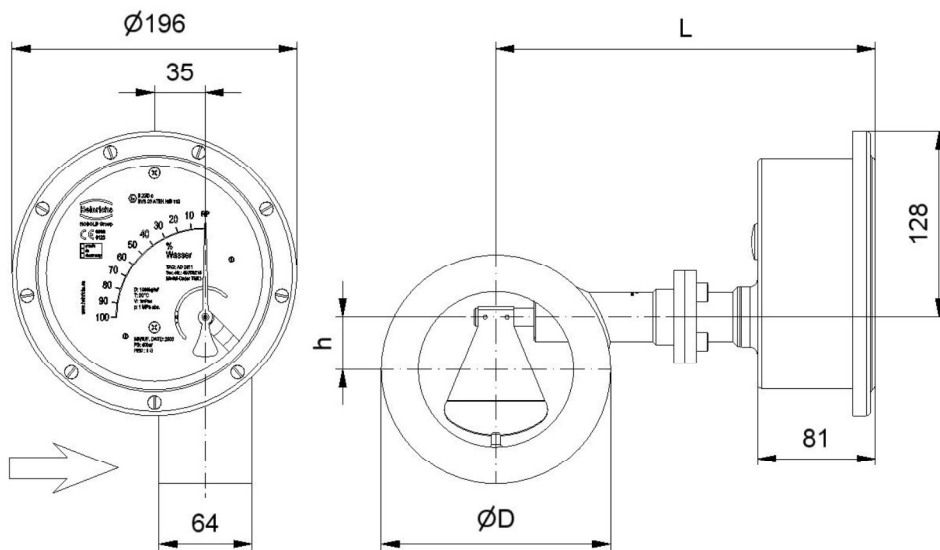

Horizontal flow from right to left

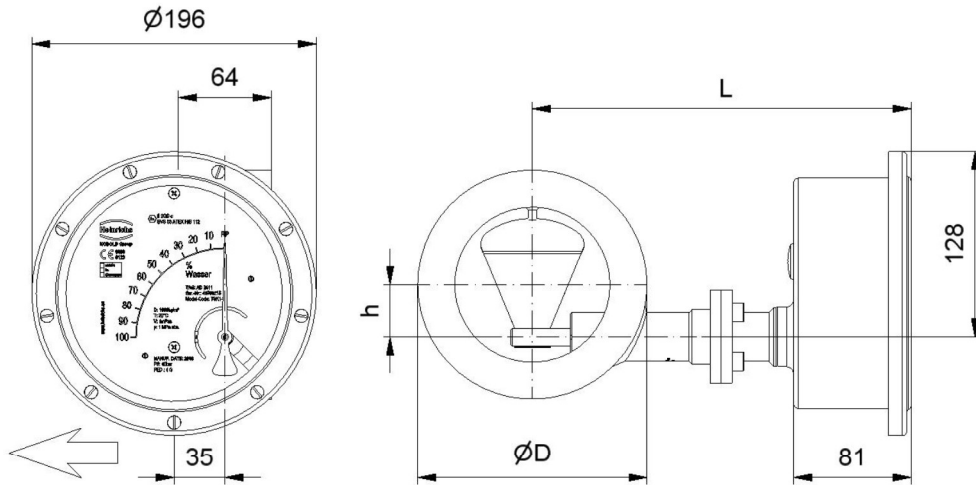

Vertical flow from top to bottom

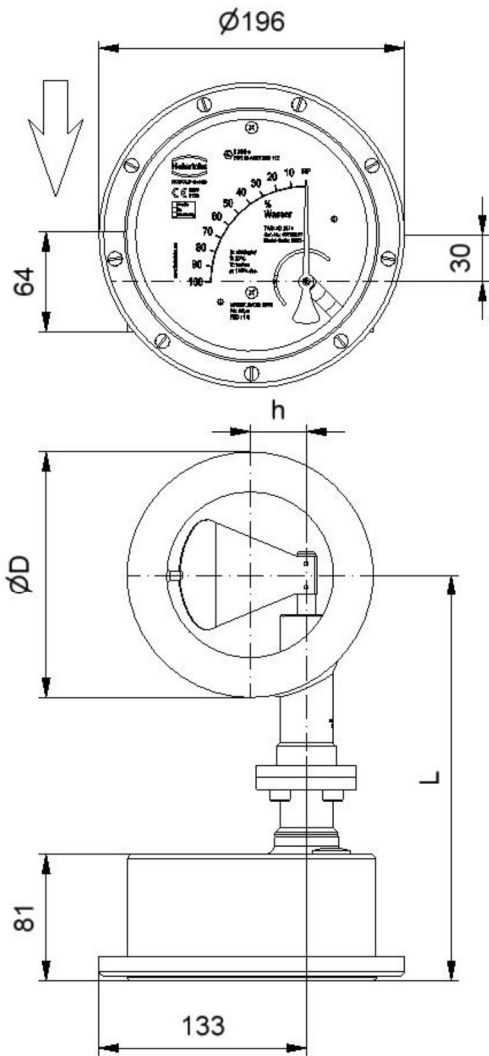

Vertical flow from bottom to top

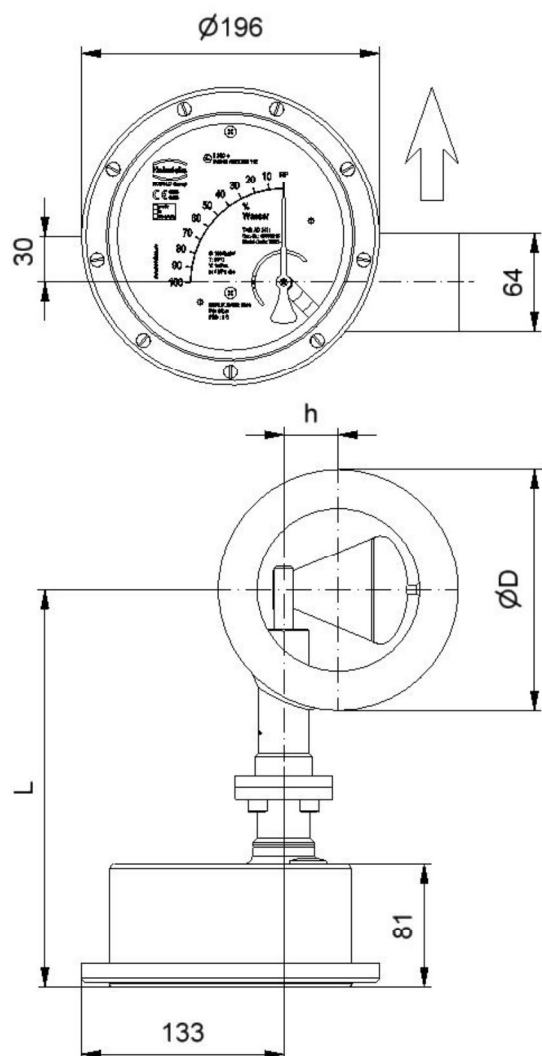

## 10.2 Dimensions TSK-C, TSK-S, TSK H

Nominal size		Nom. pressure (standard)		L [mm]		D [mm]		h [mm]
DN - DIN/EN	ASME	PN	class	Indicator Aluminum	Indicator st.st.	DIN-/EN-flange	ASME-flange	
25	-	40	-	280	255	68	-	14
40	1½"	40	300	270	245	88	73	14
50	2"	40	300	272	261	102	92,1	17
65	2½"	40	300	272	261	122	102	21 (ASME=17)
80	3"	40	300	272	261	138	127	31
100	4"	16	150	272	261	158	158	36
125	5"	16	150	352	341	186	186	45
150	6"	16	150	352	341	212	212	53
200	8"	16	150	352	341	268	268	80
250	10"	16	150	352	341	320	320	90
300	12"	10	150	372	361	370	381	100
350	14"	10	150	442	431	430	413	100
400	16"	10	150	452	441	482	470	130
500	20"	10	150	492	481	585	585	130

Indicator on distance = L + 100 mm

\*TSK-C available from DN 150 / 6"

## 10.3 Weight

DIN / ASME	Weight Typ TSK-C/S / H ca. kg
25	3,2
40 / 1½" ANSI	3,5
DN50 / 2" ANSI	4,5
DN65 / 2½" ANSI	5,5
DN80 / 3" ANSI	6,5
DN100 / 4" ANSI	7,5
DN125 / 5" ANSI	9,5
DN150 / 6" ANSI	10,5
DN200 / 8" ANSI	14
DN250 / 10" ANSI	19
DN300 / 12" ANSI	25
DN350 / 14" ANSI	31
DN400 / 16" ANSI	34
DN500 / 18" ANSI	44

## 10.4 Sealing face

The sealing surface can be supplied with groove or ring joint

## 10.5 Materials

Model	Fitting	Paddle	Axle	Spring	Socket bearing unit	c/w	Coupling Chamber	Magnet
TSK-C	Carbon steel	st.st. 316L / 316TI	st.st. 316L / 316TI	st.st. 316TI	st.st. 316L / 316TI		st.st. / 316	≥ 135°C PVDF ≤ 136°C st.st.
TSK-S	st.st. 316L / 316TI	st.st. 316L / 316TI	st.st. 316L / 316TI	st.st. 316TI / Inconel	st.st. 316L / 316TI		st.st. / 316	≥ 135°C PVDF ≤ 136°C C22 / HC4
TSK-H	Hastelloy C22 / HC4	Hastelloy C22 / HC4	Hastelloy C22 / HC4	Hastelloy HC4	Hastelloy C22 / HC4		st.st. C22/HC4 lined	≥ 135°C PVDF ≤ 136°C C22 / HC4
TSK-K	PPH	st.st. 316L / 316TI	st.st. 316L / 316TI	st.st. 316TI	PPH st.st. 316L/316TI		st.st. / 316	PVDF
TSK-J	PPH	Hastelloy C22 / HC4	Hastelloy C22 / HC4	Hastelloy HC4	PPH Hast.C22 / HC4		st.st. / 316 PPH lined	PVDF
TSK-P	PTFE	Hastelloy C22 / HC4	Hastelloy C22 / HC4	Hastelloy HC4	PTFE Hast.C22 / HC4		st.st. / 316 PTFE lined	PVDF

O-Ring / Sealing: Depending on ordered material Viton / FEP / st.st. see also model code Point 21

### Indicator unit

Model	Indicator	Base plate	Cover / sight glass	Cover sealing
TSK-C / S / H / K / J / P	Indicator Aluminum	Aluminium	Aluminium / safety glass	Buna N
TSK-C / S / H / K / J / P	Indicator st.steel	st.st.	st.steel / safety glass	Buna N

# 11 Electrical connection

## Wiring

To connect the power supply, remove the indicator cover, insert the connector cable into the cable gland and attach it to the terminals according to the terminal diagram. Tighten the cable gland securely, remount the indicator cover and close it tightly.



Please observe the following wiring instruction carefully. (Improper wiring will cause loss of guarantee)

- Cable glands are not part of the delivery
- The cable gland must fit to the cable gland thread.
- The cable gland must fit to the diameter of the cable
- The cable must form a pig tale in front of the gland to avoid water ingress - see sketch on the right
- Cable glands must not point upward
- The delivered cable gland connection sealing screw - delivered with instruments with no signal transmitter - must be removed
- The sealing of the cable glands must correspond with the instructions of the original cable gland manufacturer. Wrongly or incorrect tightened cable glands will cause water ingress into the indicator housing

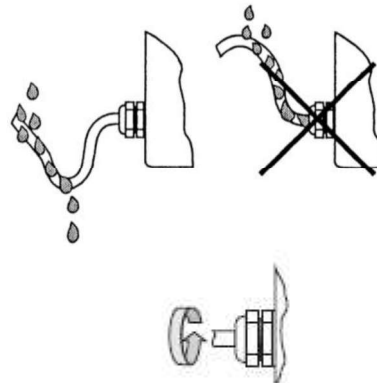

### 11.1 Wiring diagram for ES transmitter

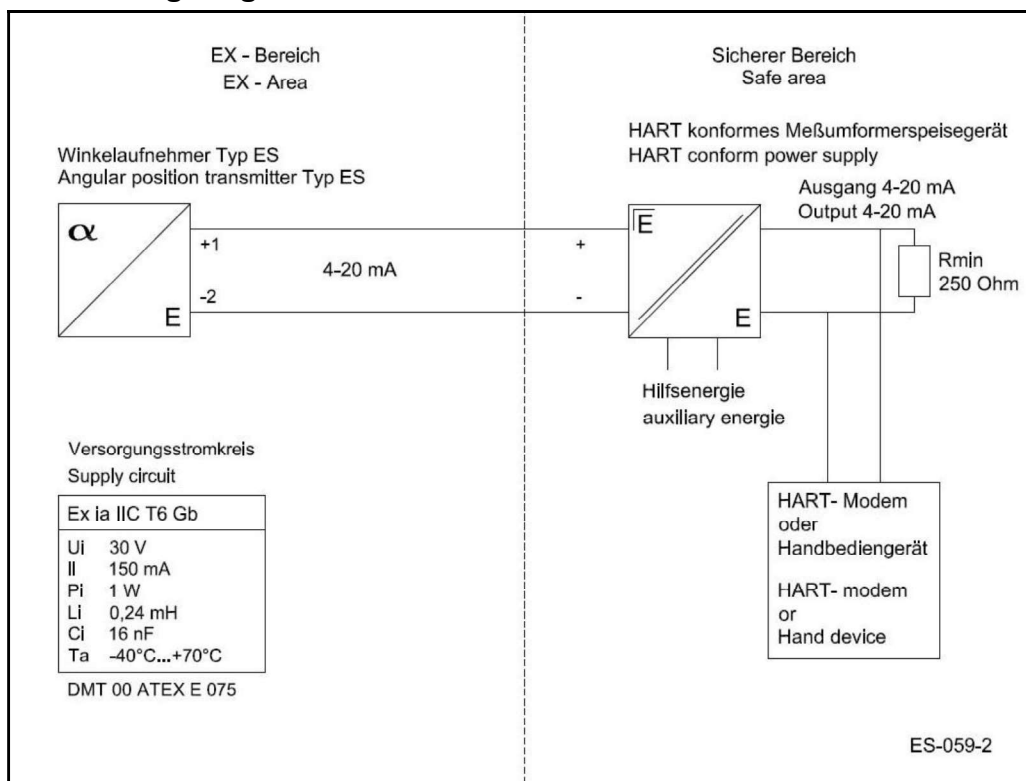

### 11.2 Wiring diagram for ES transmitter with 4-20 mA output and 2 limit transducers

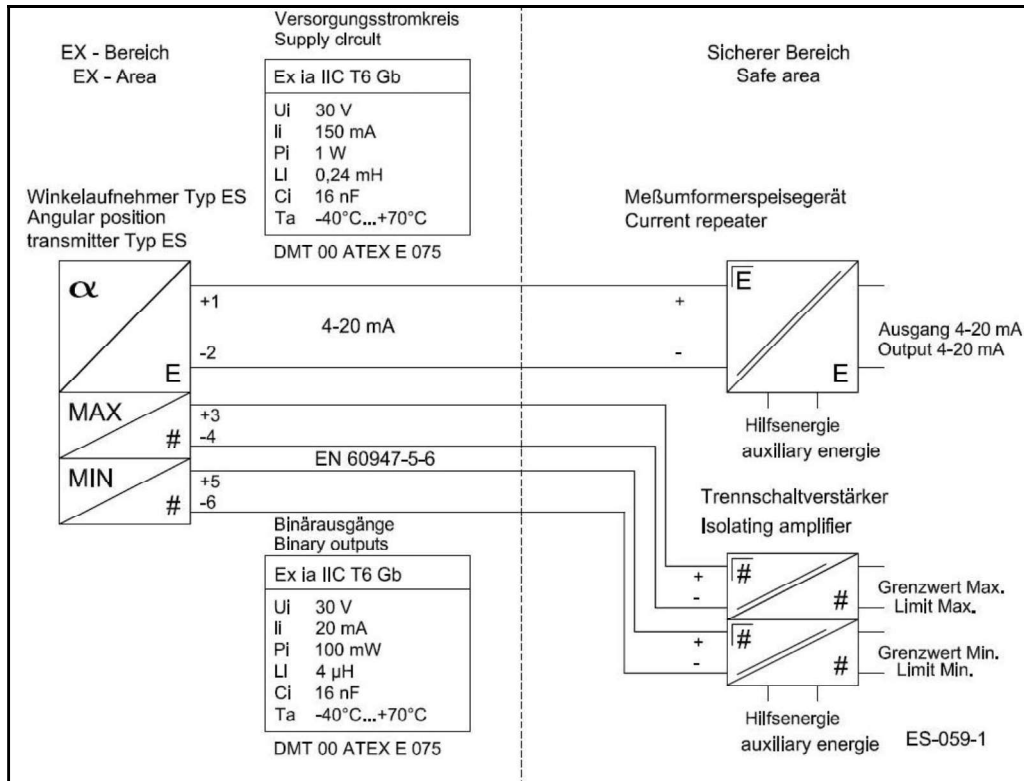

### 11.3 Wiring diagram for ES transmitter with 4- 20 mA output, pulse output and limit switches

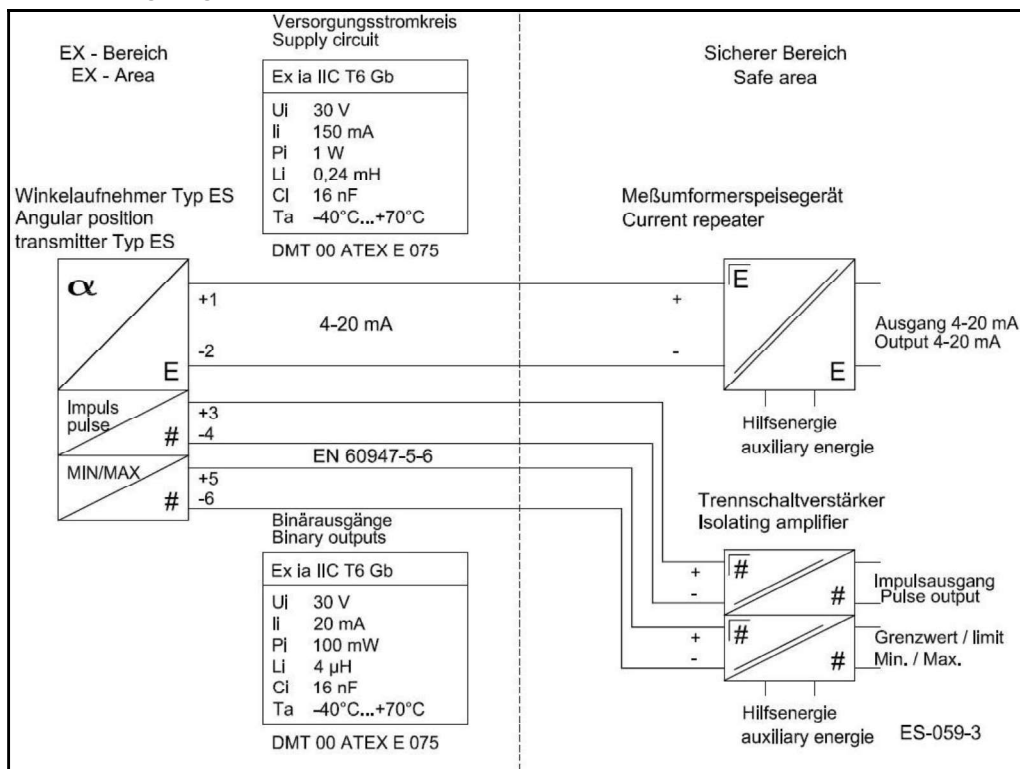

### 11.4 Wiring diagram for inductive limit switches SJ-3,5 N

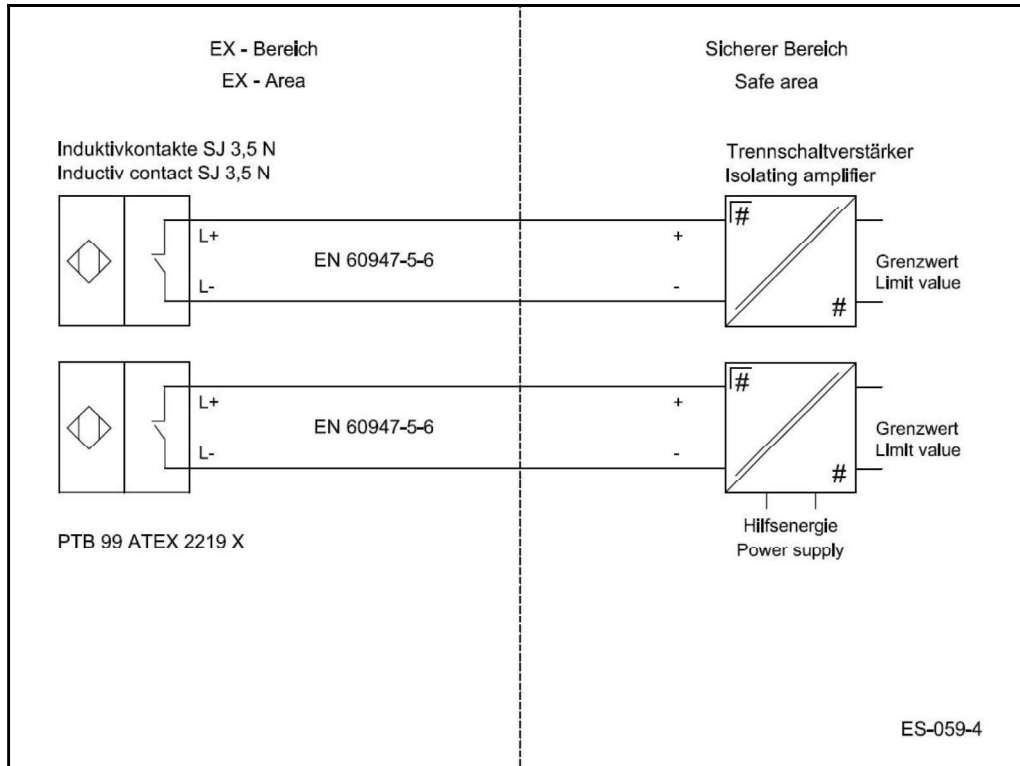

### 11.5 Wiring diagram for KEM 1 and KEM 2 micro switches

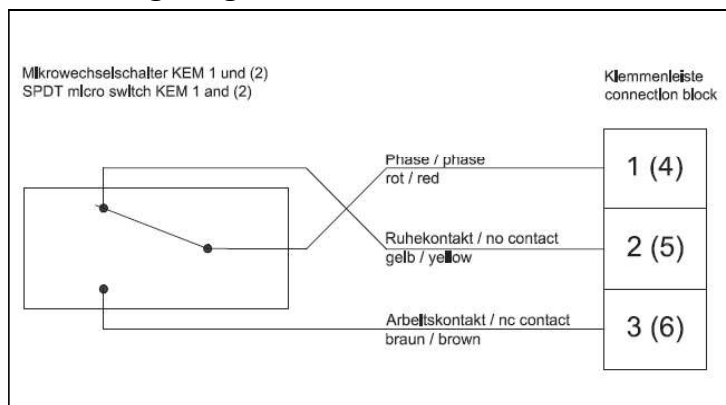

### 11.6 Devices with unconnected cable end

For simple electrical connection, especially at instruments with stainless steel indicator, the device can be supplied with a cable end (silicon cable). The standard cable length is 2.5 m. The cable has 7 wires, yellow / green for earth and 6 black wires with white numbers 1-6. The function of the wires (1-6) corresponds to the terminal numbers.

If the connection is made in a hazardous area, the cable must be connected in a housing that meets the requirements according to IEC EN 60079-14.

## 12 Power supply

see electrical connection

## 13 CE mark

The measuring system meets the statutory requirements of the following EU directives: Directive 2014/34/EU (ATEX), the Electromagnetic Compatibility (EMC) Directive 2014/30/EU (EMC) and the Pressure Equipment Directive 2014/68/EU (PED).

## 14 Order information

Please include the following information in your order: product data, specific weight, temperature, pressure, viscosity, material design, connection size, measuring range, direction of flow, desired accessories, required approvals and material certificates.

**See also device selection by model code.**

### 14.1 Available accessories

- Stainless steel indicator unit, glass window IP 67
- Indicator unit for high or low temperatures displaced ( on distance) by 100 mm
- 1 or 2 inductive limit switches
- Electrical transmitter ES with PROFIBUS PA interface
- Electrical transmitter ES with FF FIELBUS FOUNDATION interface

## 15 Standards and directives, certificates and approvals

See Declaration of Conformity Point 23

## 16 Maintenance

The device requires no maintenance if used according to its intended purpose and is largely insensitive to dirt. However, if cleaning is necessary take note of the following aspects:

- Before removing a device, make sure that the pipeline is free from the process media, is pressureless and has cooled down.
- Fittings with the inside deposits may be carefully cleaned after removal with a brush and the appropriate cleansing agent. Carefully clean the measuring body from possible coating. Attention: do not work on the paddle and the measuring body with hard objects (see Removing/installing the measuring body).
- The switching points of the limit switches are adjustable. For adjustment, remove the indicator cover, unfasten the contact point indicator located on the scale and readjust it. After the adjustment, reattach the bolts of the contact point indicator. Reinstall and tighten the indicator cover.
- The parameterization of the ES is possible and is done via HART®. Please refer to the separate Operating Instructions for the ES.

## 17 Trouble shooting

Diagnosis	Possible reason	Corrective action
<b>Indicator window steamed</b>	indicator cover damaged indicator sealing damaged cable gland not tightened high temperature differences aggressive ambient atmosphere	- change indicator cover  - tighten cable gland - indicator with pressure relief - install rinsing connection for N2 gas
<b>Indicator cover untight</b>	indicator sealing damaged	- change indicator cover - fasten indicator cover screws
<b>Indicator window icy</b>	ambient temperature too low	- install N23 rinsing connection - change to high tem. distance housing
<b>Instrument shows wrong measuring values</b>	calibration does not meet process conditions pointer de-adjusted	- review operating conditions, on deviations new calibrations from manufacturer is recommended - re-adjust pointer (RP on meas. scale)
<b>No reaction on pointer despite flow</b>	pointer is behind the stopper ( RP) float is stucked (pollution)	- remove cover, re-adjust pointer - remove instrument from process and clean paddle and all inner parts carefully - if sticking parts in the process use of magnet filter recommended
<b>Paddle is stucked</b>	pollution / residues in the process paddle / axle damaged	- remove instrument from the process and clean carefully - resend the instrument to the manufacturer for evaluation
<b>Pointer indication is pulsating</b>	inlet pressure too low	- increase inlet pressure, instrument for recalibration back to manufacturer (gases) or - use of instrument with low pressure loss - re-equip with double turbulent flow damping - locate valves, gate valves etc. after the instrument
<b>Electrical equipment e.g. transducer, limit switches w/o function</b>	wrong wiring defective electrical. parts	- check wiring diagram acc. instruction manual - change el. parts ( e.g. limit switches ) or sent the instrument back to manufacturer
<b>Un-known</b>		Sent the instrument back to the manufacturer and include a detailed failure description

## 18 Returning devices for repair and service

### Note:

In accordance with the applicable German waste disposal legislation, the owner/client is responsible for the disposal of special waste and hazardous materials.



Consequently, all devices sent to us for repair must be free of any hazardous materials. This also applies to possible hollow spaces and fissures in the devices. If repair is necessary, confirm the above-mentioned item in writing (**please use the form in the appendix**).

If hazardous materials remain in or on the device after it has been returned, Heinrichs Messtechnik shall be authorized to remove them at the client's expense without further inquiry.

## 19 Spare parts

The following parts can be ordered as replacement parts:

- 1 ) Indicator cover with window/gasket/screws
- 2 ) Scale with standard scaling
- 3 ) Pointer
- 4 ) Limit switch indicator
- 5 ) Pointer stop
- 6 ) Limit switch
- 7 ) Electrical transmitter EX / -Profibus PA / Fieldbus Foundation

## 20 Explosion drawings

### 20.1 Indicator unit

Name	Part no.
Indicator base plate 1 x M 20 x 1.5	10
Inner earthing connection	15
Bearing assembly	20
Fixing screws for bearing unit	30
Dummy plug M 20 x 1.5 c/w o-ring	40
Cable gland blue (intrinsically safe ) c/w o-ring M20 x 1,5	41
Cable gland grey (ATEX) c/w o-ring M20 x 1,5	42
Scale, blank	50
Fixing screw for the scale	60
Zero-point screw with nut	70
Indicator cover with glass window, gasket, screws	80
Scale pointer	90
Scale pointer c/w 1 switching disc KEI	91
Scale pointer c/w 2 switching discs KEI	92
Scale pointer c/w 1 switching disc KEM	93
Scale pointer c/w 2 switching discs KEM	94
Scale pointer c/w ES position magnet	95
1. SJ 3,5 N limit switch c/w limit value indicator incl. c/w mounting parts	110
1 SPDT micro switch KEM 1 c/w mounting parts	114
2. SJ 3,5 N limit transducer with limit value indicator	120
2 SPDT micro switches KEM 2 c/w mounting parts	124
Distortion lock c/w screw	130
Installation assembly for 1 micro switch KEM 1	131
Installation assembly for 2 micro switches KEM 2	132
ES HART® transmitter c/w fixing screws	140

**20.1.1 Complete Indicator unit with local scale**

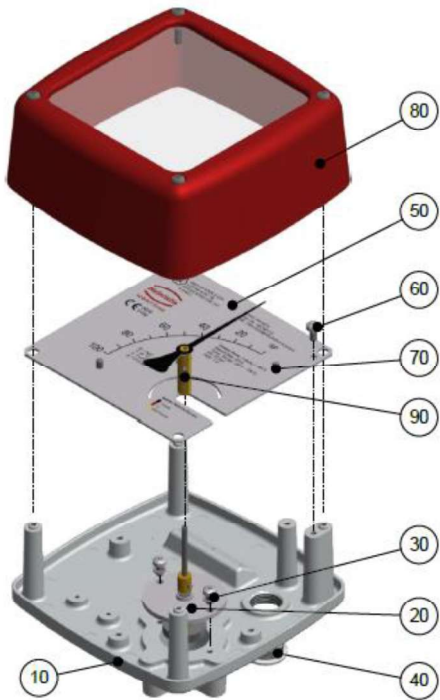

**20.1.3 Complete Indicator unit with 2 pcs limit switch KEI (SJ 3,5-N)**

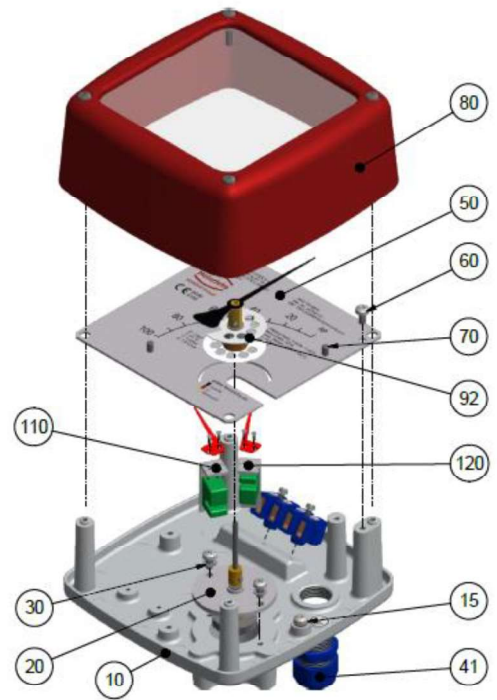

**20.1.2 Complete indicator unit, c/w 1 pc limit switch KEI (SJ 3,5-N)**

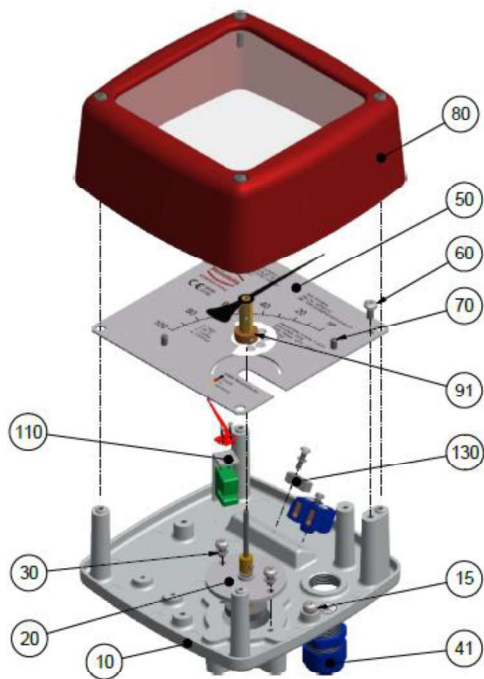

**20.1.4 Complete indicator unit with 2 pcs SPDT micro switch KEM**

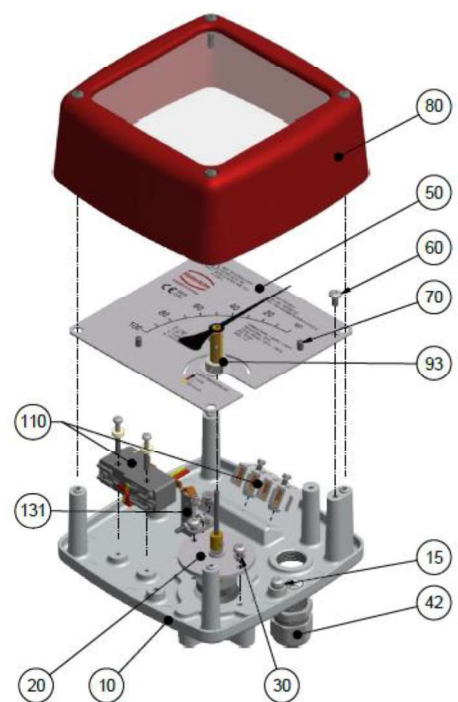

20.1.5 Complete indicator unit with 1 pc SPDT micro switch KEM

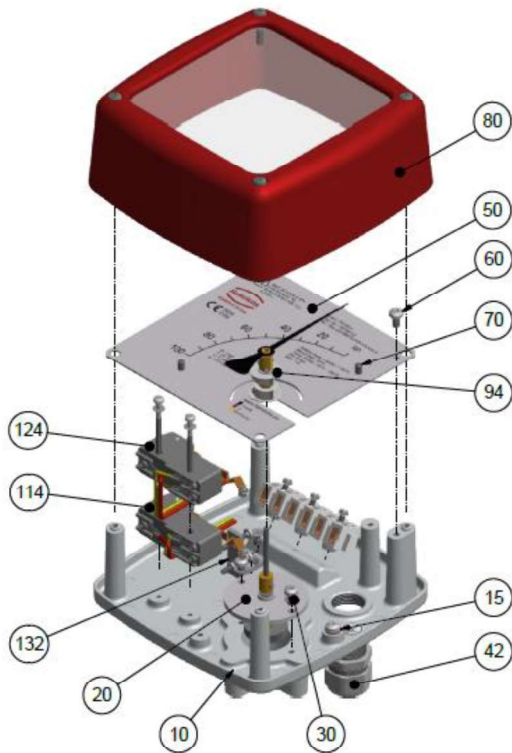

20.1.6 Complete indicator with transmitter ES Ex HART

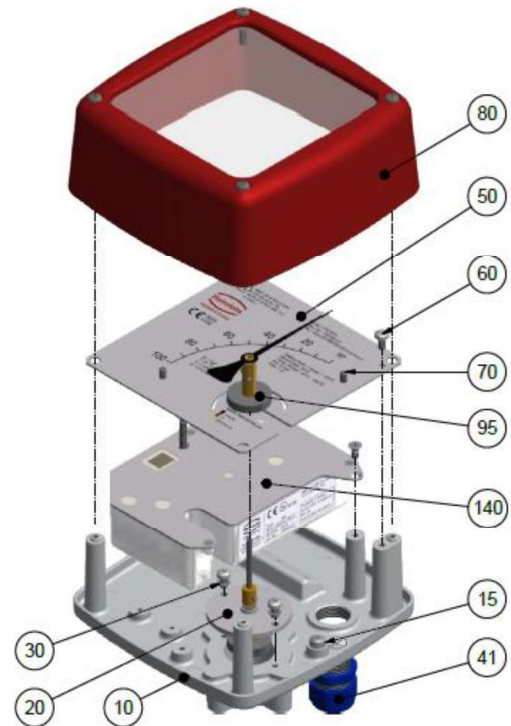

21 Model Code

Model code	Description		Pressure rating	Process temperature
TSK				
-				
	<b>Wetted Parts</b>			
S	Fitting: st.st.	Built in parts: st.st.	40 bar	-40° up to +300°C
H	Fitting: Hastelloy C-22	Built in parts: Hastelloy C-22	40 bar	-40° up to +300°C
K	Fitting: PP	Built in parts: st.st.	16 bar	0° up to +80°C
J	Fitting: PP	Built in parts: Hastelloy C-22	16 bar	0° up to +80°C
P	Fitting: PTFE	Built in parts: Hastelloy C-22	16 bar	-20° up to +125°C
	<b>Process connection</b>			
<b>DN25/</b>	309B	DN25 PN40 Form B1 DIN EN 1092-1		
<b>1"</b>	203R	1" Class 150 RF ASME B16.5-2003		
	223R	1" Class 300 RF ASME B16.5-2003		
	309D	DN25 PN40 Form D DIN EN 1092-1		
	203J	1" Class 150 RTJ ASME B16.5-2003		
	223J	1" Class 300 RTJ ASME B16.5-2003		
<b>DN40/</b>	317B	DN40 PN40 Form B1 DIN EN 1092-1		
<b>1 1/2"</b>	205R	1 1/2" Class 150 RF ASME B16.5-2003		
	225R	1 1/2" Class 300 RF ASME B16.5-2003		
	317D	DN40 PN40 Form D DIN EN 1092-1		
	205J	1 1/2" Class 150 RTJ ASME B16.5-2003		
	225J	1 1/2" Class 300 RTJ ASME B16.5-2003		
<b>DN50/</b>	321B	DN50 PN40 Form B1 DIN EN 1092-1		
<b>2"</b>	206R	2" Class 150 RF ASME B16.5-2003		
	226R	2" Class 300 RF ASME B16.5-2003		
	321D	DN50 PN40 Form D DIN EN 1092-1		
	206J	2" Class 150 RTJ ASME B16.5-2003		
	226J	2" Class 300 RTJ ASME B16.5-2003		
<b>DN65/</b>	326B	DN65 PN40 Form B1 DIN EN 1092-1		

<b>2 1/2"</b>	207R	2 1/2" Class 150 RF ASME B16.5-2003			
	227R	2 1/2" Class 300 RF ASME B16.5-2003			
	326D	DN65 PN40 Form D DIN EN 1092-1			
	207J	2 1/2" Class 150 RTJ ASME B16.5-2003			
	227J	2 1/2" Class 300 RTJ ASME B16.5-2003			
<b>DN80/</b>	331B	DN80 PN40 Form B1 DIN EN 1092-1			
<b>3"</b>	208R	3" Class 150 RF ASME B16.5-2003			
	228R	3" Class 300 RF ASME B16.5-2003			
	331D	DN80 PN40 Form D DIN EN 1092-1			
	208J	3" Class 150 RTJ ASME B16.5-2003			
	228J	3" Class 300 RTJ ASME B16.5-2003			
<b>DN100/</b>	335B	DN100 PN16 Form B1 DIN EN 1092-1			
<b>4"</b>	210R	4" Class 150 RF ASME B16.5-2003			
	230R	4" Class 300 RF ASME B16.5-2003			
	335D	DN100 PN16 Form D DIN EN 1092-1			
	210J	4" Class 150 RTJ ASME B16.5-2003			
	230J	4" Class 300 RTJ ASME B16.5-2003			
<b>DN125/</b>	340B	DN125 PN16 Form B1 DIN EN 1092-1			
<b>5"</b>	211R	5" Class 150 RF ASME B16.5-2003			
	231R	5" Class 300 RF ASME B16.5-2003			
	340D	DN125 PN16 Form D DIN EN 1092-1			
	211J	5" Class 150 RTJ ASME B16.5-2003			
<b>DN150/</b>	345B	DN150 PN16 Form B1 DIN EN 1092-1			
<b>6"</b>	212R	6" Class 150 RF ASME B16.5-2003			
	232R	6" Class 300 RF ASME B16.5-2003			
	345D	DN150 PN16 Form D DIN EN 1092-1			
	212J	6" Class 150 RTJ ASME B16.5-2003			
	232J	6" Class 300 RTJ ASME B16.5-2003			
<b>DN200/</b>	350B	DN200 PN16 Form B1 DIN EN 1092-1			
<b>8"</b>	213R	8" Class 150 RF ASME B16.5-2003			
	350D	DN200 PN16 Form D DIN EN 1092-1			
	213J	8" Class 150 RTJ ASME B16.5-2003			
<b>DN250/</b>	356B	DN250 PN16 Form B1 DIN EN 1092-1			
<b>10"</b>	214R	10" Class 150 RF ASME B16.5-2003			
	355D	DN250 PN10 Form D DIN EN 1092-1			
	214J	10" Class 150 RTJ ASME B16.5-2003			
<b>DN300/</b>	362B	DN300 PN10 Form B1 DIN EN 1092-1			
<b>12"</b>	215R	12" Class 150 RF ASME B16.5-2003			
	362D	DN300 PN10 Form D DIN EN 1092-1			
	215J	12" Class 150 RTJ ASME B16.5-2003			
<b>DN350/</b>	369B	DN350 PN10 Form B1 DIN EN 1092-1			
<b>14"</b>	216R	14" Class 150 RF ASME B16.5-2003			
	369D	DN350 PN10 Form D DIN EN 1092-1			
	216J	14" Class 150 RTJ ASME B16.5-2003			
<b>DN400/</b>	375B	DN400 PN10 Form B1 DIN EN 1092-1			
<b>16"</b>	217R	16" Class 150 RF ASME B16.5-2003			
	375D	DN400 PN10 Form D DIN EN 1092-1			
	217J	16" Class 150 RTJ ASME B16.5-2003			
<b>DN500/</b>	380B	DN500 PN10 Form B1 DIN EN 1092-1			
<b>18"</b>	219R	20" Class 150 RF ASME B16.5-2003			
	380D	DN500 PN10 Form D DIN EN 1092-1			
	219J	20" Class 150 RTJ ASME B16.5-2003			
		<b>Measuring range</b>			
	xxx	Acc. To measuring range table			
		<b>Flow direction</b>			
	U	Bottom to top			
	O	Top to bottom			
	L	Left to right			
	R	Right to left			
		<b>Temperature class</b>		<b>Model</b>	
	6	max. 80°C	Contains: enclosure of magnet PVDF	K, J	
	5	max. 100°C	Contains: enclosure of magnet PVDF		
	4	max. 135°C	Contains: display forward advanced, enclosure of magnet PVDF		
	3	max. 200°C	Contains: display forward advanced, stainless steel enclosure of magnet		
	2	max. 300°C	Contains: display forward advanced, stainless steel enclosure of magnet, spring Inconel, stainless steel sealing		
		<b>Sealing</b>		<b>Process temperature</b>	
	V	Viton		max. 150°C	
	F	FEP		max. 200°C	

	S	Stainless steel			max. 300°C	
		<b>Protection against particle-penetration into transmission chamber</b>			<b>Process temperature</b>	
	0	without				
	1	with (Viton)			max. 150°C	
	2	with (FEP)			max. 200°C	
	-					
		<b>Certificate</b>				
	0	without				
	1	Certificate of compliance with the order, 2.1				
	2	Test report, 2.2				
	B	Inspection certificate 3.1 with material certificate (DIN EN 10204:2004)				
	C	Inspection certificate 3.2 with material certificate (DIN EN 10204:2004)				
	N	NACE Materialcertificate				
	-					
		<b>Indicating part</b>				
	S	Standard indicating housing (aluminum)				
	E	Stainless steel indicating housing IP67				
	T	Standard indicating housing (aluminum) with pressure compensation				
		<b>Product scale</b>				
	1	% -Scale (Water)				
	2	Measuring range-Scale (Water)				
	F	Double-scale (acc. customer preference)				
	4	% -Scale (Media)				
	5	Measuring range-Scale (Media)				
	7	Oil scale	measuring ranges on request			
		<b>Electrical output</b>			<b>Ambient temperature</b>	
	0	without			-40° to +80°C	
	1	1 x inductive switch, Type SJ 3,5 N			-40° to +65°C	SIL1 <sup>10)</sup>
	2	2 x inductive switch, Type SJ 3,5 N			-40° to +65°C	SIL1 <sup>10)</sup>
	3	1 x inductive switch, Type SJ 3,5 SN (safety design)			-40° to +65°C	SIL1 <sup>10)</sup>
	4	2 x inductive switch, Type SJ 3,5 SN (safety design)			-40° to +65°C	SIL1 <sup>10)</sup>
	6	Transmitter ES with HART-protocol, 4-20 mA, EEx ia			-40° to +70°C	SIL1 <sup>10)</sup>
	7	Transmitter ES with HART-protocol, 4-20 mA, EEx ia / 2x NAMUR-switch			-40° to +70°C	SIL1 <sup>10)</sup>
	8	Transmitter ES with HART-protocol, 4-20 mA, EEx ia / 1x NAMUR-switch, 1x pulse output			-40° to +70°C	SIL1 <sup>10)</sup>
	9	Transmitter ES with Profibus PA, EEx ia			-40° to +70°C	
	A	Transmitter KINAX 3W2, 0/4-20mA, EEx ia			-40° to +80°C	
	B	Transmitter KINAX 3W2, 0/4-20mA, EEx ia, add. ind. switch SJ 3,5 SN (safety design)			-40° to +80°C	
	C	1 x microswitch			-40° to +65°C	
	D	2 x microswitch			-40° to +65°C	
	E	1 x inductive switch, Type SB 3,5-E2, three wire			-40° to +65°C	
	F	2 x inductive switch, Type SB 3,5-E2, three wire			-40° to +65°C	
	G	Proximity switch NCB2-12GM40-ZO			-25° to +70°C	
	I	Transmitter ES with HART-protocol and counter module			-40° to +70°C	
	K	Transmitter ES Fieldbus Foundation			-40° to +70°C	
	X	special model				
	-					
		<b>Accessory</b>				
	0	without				
	X	with (separate specification necessary)				
	-					
		<b>Design</b>				
	H	Heinrichs				
	K	Kobold				

**22 Decontamination certificate for device cleaning**

Company: ..... Name: .....

Street: ..... Tel.-Nr.: .....

Postal code..... / Town: .....

The Paddle Type Flow Meter Model .....

<b>Comm.-Nr. / Ser.-Nr.:</b>	
------------------------------	--

has been used with media :.....

As the used media is :

- harmless
- toxic
- harmful
- caustic
- radioactive
- explosive
- oxidizing
- biological harmful
- other .....

we have doen the following things:

- all cavities have been tested to be free the used process media
- all cavities are rinsed and neutralized
- all sealing surfaces and wetted parts have been cleaned
- instrument housing and surfaces have been completely cleaned

**We herewith confirm that due to the re-delivery of the above mentioned instrument there is no danger for human and environment which may be caused by residues of the process media.**

Date: .....

Signature: .....

Stamp