

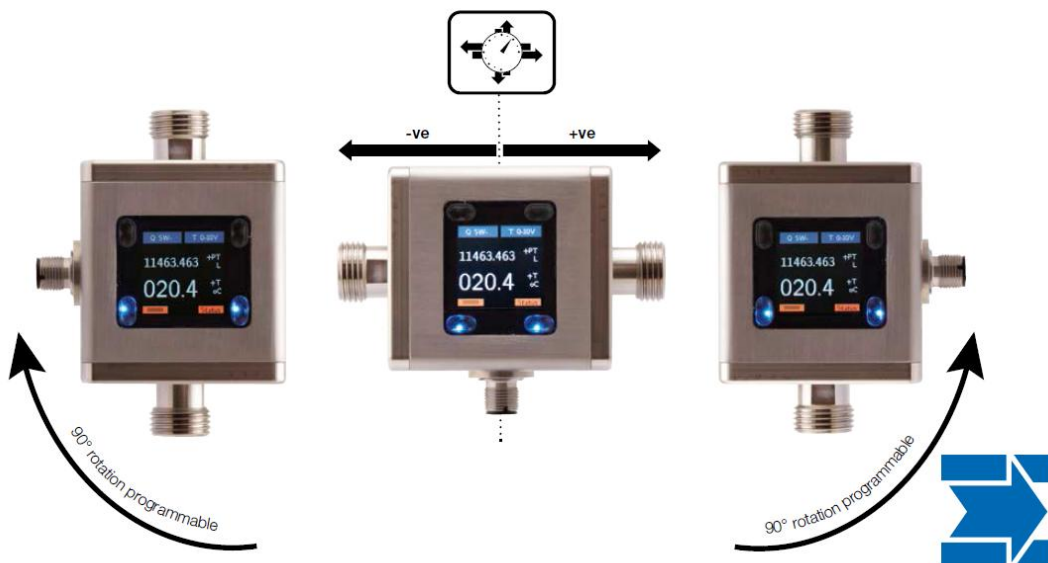

# Operating Instructions for Magnetic Inductive Flowmeter Model: MIM



We don't accept warranty and liability claims neither upon this publication nor in case of improper treatment of the described products.

The document may contain technical inaccuracies and typographical errors. The content will be revised on a regular basis. These changes will be implemented in later versions. The described products can be improved and changed at any time without prior notice.

© **Copyright**

**All rights reserved.**

## 1. Contents

---

1. Contents.....	2
2. Note .....	4
2.1 General.....	4
2.2 Validity and version of the operating instructions.....	4
2.3 Hazard warnings.....	4
2.4 As per PED 2014/68/EU .....	5
2.5 Overview of the device functionality.....	5
3. Instrument Inspection.....	6
4. Intended Use.....	6
5. Environment.....	7
6. Operating principle.....	8
6.1 General.....	8
6.2 Minimum electrical conductivity / Gas bubbles .....	8
6.3 Deposits.....	8
6.4 Measuring electrodes .....	9
7. Mechanical connection.....	9
7.1 Check operating conditions.....	9
7.2 Installation.....	9
8. Electrical Connection .....	12
8.1 General.....	12
8.2 Pin assignment .....	13
8.3 Connection example outputs: .....	17
9. Operation and menu structure .....	18
10. Status.....	19
11. IO-Link function .....	20
11.1 Specification .....	21
12. Technical Information.....	22
13. Order Codes .....	22
14. Dimensions .....	22
15. Disposal .....	22
16. Appendix.....	23
1. Manufacturer's declaration.....	25
2. Confirmation for contact with drinking water .....	26
3. EU Declaration of Conformance .....	27
4. UK Declaration of Conformity.....	28

**Manufactured and sold by:**

Kobold Messring GmbH  
Nordring 22-24  
65719 Hofheim  
Tel.: +49(0)6192-2990  
Fax: +49(0)6192-23398  
E-Mail: [info.de@kobold.com](mailto:info.de@kobold.com)  
Internet: [www.kobold.com](http://www.kobold.com)

## 2. Note

### 2.1 General

Before unpacking and commissioning the device, the operating instructions and the “General Safety Instructions” document must be read and followed carefully. The general safety instructions, the operating instructions, the data sheet as well as approvals and further information can be downloaded via the QR code on the device or under the respective product on [www.kobold.com](http://www.kobold.com).

Operating instructions, data sheet, approvals and further information via the QR code on the device or via [www.kobold.com](http://www.kobold.com)

The devices are only to be used, maintained and serviced by persons familiar with these operating instructions and in accordance with local regulations applying to Health & Safety and prevention of accidents.



When used in machines, the device should be used only when the entire machine fulfils the EU machinery directive.





### 2.2 Validity and version of the operating instructions

Due to technical changes, the device documentation available online may not always correspond to the product version you have purchased. If you need an instruction manual that corresponds to the purchased product version, you can request it from us free of charge by email ([info.de@kobold.com](mailto:info.de@kobold.com)) in PDF format, specifying the relevant invoice number and serial number. If you wish, the operating instructions can also be sent to you by post in paper form.

### 2.3 Hazard warnings

The following instructions are intended to ensure your personal safety and to prevent damage to the product described or connected devices. Safety instructions and warnings to prevent danger to the life and health of users or maintenance personnel, or to prevent damage to property, are highlighted in this documentation using the symbols defined here. *The symbols and terms used have the following meaning in the documentation itself:*

Symbol	Explanation	Symbol	Explanation
 Note	Is important information about the product, the handling of the product or the respective part of the documentation to which particular attention should be drawn.	 Caution	Means that minor personal injury or minor property damage may occur if proper precautions are not taken.

Symbol	Explanation	Symbol	Explanation
 Warning	Indicates that serious personal injury or substantial property damage may occur if proper precautions are not taken.	 Danger	Means that death can occur if proper precautions are not taken.
 Warning	Attention: Hot surface!	 Warning	Warning: Dangerous electrical voltage

## 2.4 As per PED 2014/68/EU

In acc. with Article 4 Paragraph (3), "Sound Engineering Practice", of the PED 2014/68/EU no CE mark.

Diagram 8, Pipe, Group 1 dangerous fluids

## 2.5 Overview of the device functionality

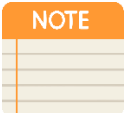
 <b>NOTE</b>	Depending on the installed device firmware, the MIM device may have different functionalities. The functional extensions are shown in the following table.
Note	

Function extension	Available from firmware version
Dosing function	REV180118
Menu languages Simulation function User function keys Analogue output 2-10 V <sub>DC</sub> Analogue output behavior acc. to NAMUR NE43	REV180514
IO-Link Control input	REV190320
Additional flow units L/s and mL/s	REV191030
Filter function for flow and temperature measurement	REV200608
Volume counter overflow increased to 9.999999E9 liters	REV230615

The installed software version is displayed after starting the device below the manufacturer logo in the form REVxxxxxx for approx. 2 sec.

## 3. Instrument Inspection

---

Instruments are inspected before shipping and sent out in perfect condition. Should damage to a device be visible, we recommend a thorough inspection of the delivery packaging. In case of damage, please inform your parcel service / forwarding agent immediately, since they are responsible for damages during transit.

### **Scope of delivery:**

The standard delivery includes:

- Electromagnetic Flowmeter      model: MIM

## 4. Intended Use

---

The MIM flowmeter has been specially developed for the measurement, display and transmission of both, flow rates and temperature of conductive liquids. The instrument has a graphic TFT display, rotatable in 90 ° steps and can display flow rate, temperature, daily volume counter (resettable) and total volume counter in the units of measurement selected by the operator. A clear menu guides the user through the parameterization of the device, which largely eliminates the need to look into the operating instructions.

Flawless operation of the device can only be guaranteed if all aspects in these operating instructions are adhered to.

The manufacturer assumes no responsibility for any damage resulting from improper use. The user assumes all responsibility for such usage.

## 5. Environment

---

The MIM device with stainless steel housing is weatherproof and conforms to protection class IP67. The meter is designed for industrial environments and complies with Directive 2014/30/EU (Electromagnetic Compatibility).

**The device is intended for indoor use (relative humidity <100 %, use at up to 2000 m above sea level).**

To avoid moisture in the device from condensation, a pressure compensation membrane is integrated on the front. This membrane must not be pierced.

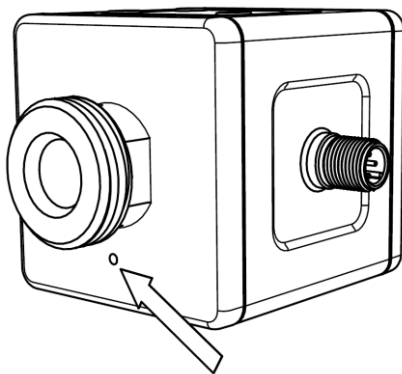

## 6. Operating principle

### 6.1 General

The new KOBOLD MIM Flowmeter is designed to measure and monitor small and medium flows of conductive fluids in piping.

The device works on the magnetic-inductive measuring principle. According to Faraday's law of induction, a voltage is induced in a conductor moving in a magnetic field. The electrically conductive measuring medium corresponds to the moving conductor in the process. The voltage induced by the measuring medium is proportional to the flow rate and thus a measure of the volume throughput. Prerequisite is a minimum electrical conductivity of the flowing medium. The induced voltage is fed to a measuring amplifier via two electrodes, which are in conductive contact with the medium. The volume flow is calculated via the defined pipe diameter.

The measurement is independent of the medium and its physical properties such as density, viscosity and temperature. The device can be configured via the display. There are two outputs available, which can each be configured as alarm, frequency, pulse, voltage, and current outputs.

The device also provides a dosing function. The dosing function can be activated in measuring mode via the four buttons. The dosing function controls simple filling tasks and also measures flow rate and partial amount.

### 6.2 Minimum electrical conductivity / Gas bubbles

For the correct function of the instrument, it is necessary that the flow channel is always completely filled with medium. From a minimum electrical conductivity of 20  $\mu\text{S} / \text{cm}$ , the MIM operates within the specified error limits. If the conductivity of the medium falls below the specified minimum conductivity value, this is signaled by displaying the error message 'Empty pipe' and the flow rate reading is set to '0'. Air bubbles in the flowing medium or media with varying conductivity in the range of the minimum conductivity can disturb the measuring function and reduce the measuring accuracy of the MIM. Gases contained in the liquid are also measured as a flow volume and lead to measurement errors. If necessary, install appropriate vents in the flow of the unit.

	<p>The conductivity of a medium decreases with its temperature. Ensure that the conductivity of your medium meets the minimum conductivity requirements across the entire temperature range of the measuring device.</p>
<p>Note</p>	

### 6.3 Deposits

Minor deposits on the measuring tube generally do not affect the measuring accuracy unless their conductivity deviates significantly from the liquid. For liquids that have a tendency to deposit, periodically inspect the meter tube and, if necessary, clean it.

## 6.4 Measuring electrodes

The MIM uses electrodes with galvanic tapping. They are in direct contact with the medium. The standard electrodes are made of stainless steel 1.4404.

In very rare cases (e.g. oils or fats in the metered medium), electrically insulating deposits on the meter electrodes cannot be ruled out. Such deposits would cause a failure of the meter.

In such cases, the electrodes must be cleaned with a soft brush and a grease solvent.

## 7. Mechanical connection

---

### 7.1 Check operating conditions

- flow rate
- max. operating pressure
- max. operating temperature

In general, MIM is subjected to the same loads as the piping into which it is installed. The MIM should therefore be kept away from extreme loads, such as pressure surges with strong, dynamic pipe movements, vibrations in the proximity of centrifugal pumps, high temperature media, flooding etc.

### 7.2 Installation

- Remove all packing materials and transport retainers and ensure that no such materials remain in the device.
- It can be installed in vertical, horizontal or rising pipes. Flow in direction of the arrow.
- Avoid pressure and tensile load.
- Mechanically secure the inlet and outlet pipe at a distance of 50 mm from the connections.
- Avoid valves or large reduction on the inlet section (this increases the inaccuracy of measurements).
- Check the leak tightness of the connections.

 Note	While mounting MIM hold the flowmeter from spanner surface (not from the housing) with the help of spanner. Take into account the tightening torque.
---	---

Nominal size	Tightening torque
1/4"	16 to 18 Nm
1/2"	22 to 24 Nm
3/4"	28 to 30 Nm
1"	28 to 30 Nm
2"	30 to 32 Nm

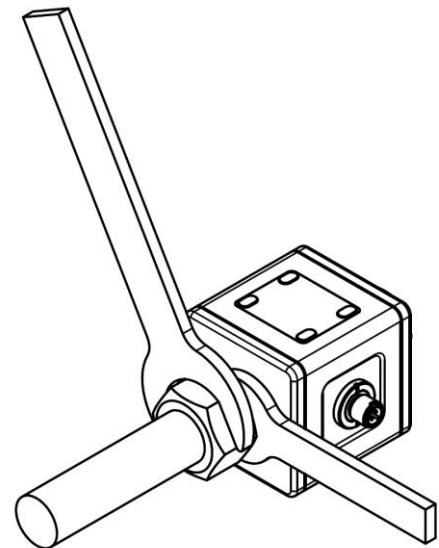

### Inlet and outlet run

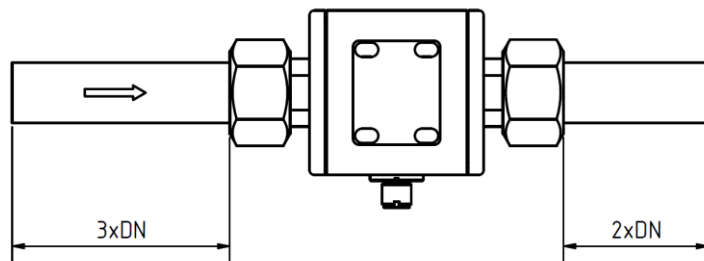

### Installation from top to bottom

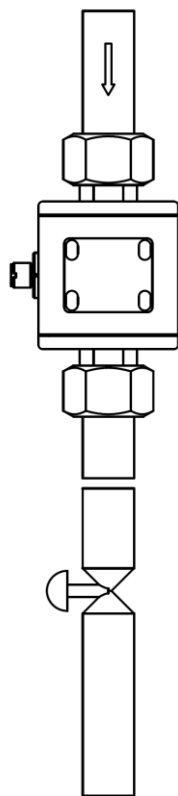

### avoid these installation locations

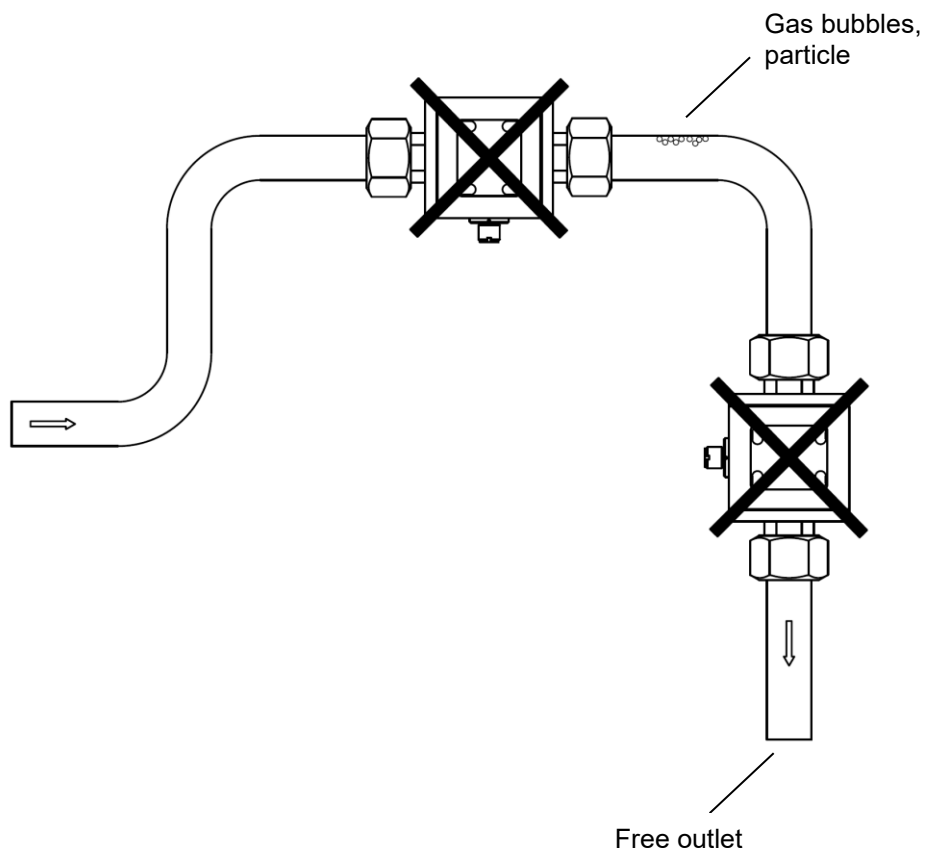

### **7.2.1 Cable Routing Option Pxx / Exx with Separate Versions**

- Remove the cable ties
- Lay the cable without loops
- Prefer a fixed cable routing
- Minimum bending radius
  - Option Pxx
    - Loose routing: 100 mm
    - Fixed routing: 50 mm
  
  - Option Exx
    - Loose routing: 102 mm
    - Fixed routing: 28 mm

## 8. Electrical Connection

### 8.1 General

<p><b>NOTE</b></p>  <p>Note</p>	<p>Attention! Make sure that the voltage values of your system correspond with the voltage values of the measuring unit.</p>
--	--

- Make sure that the supply wires are de-energised.
- Connect the supply voltage and the output signal **to the plug PIN's as stated below.**
- We recommend the use of wires with cross sectional area of min. 0.25 mm<sup>2</sup>.

<p><b>NOTE</b></p>  <p>Note</p>	<p>Attention! The measuring electrodes are galvanically connected with the reference potential of the supply voltage and the signal output.</p>
--	---

#### 8.1.1 Grounding/ Earthing

If the device is installed in a continuously grounded / earthed metallic pipe, no additional grounding / earthing of the housing is generally necessary. When installing in a plastic pipe or any ungrounded pipe, the housing must be earthed at the side threaded hole (M4) to ensure proper functionality of the MIM. **If a class 2 switched-mode power supply (all-insulated, without an external protective earth connection) is used for the power supply, the grounding must be connected to ensure functionality.** A M4 screw (thread length max. 8 mm), a matching washer, a ring cable lug and a toothed lock washer are required for correct installation.

These mechanical parts are not part of the delivery.

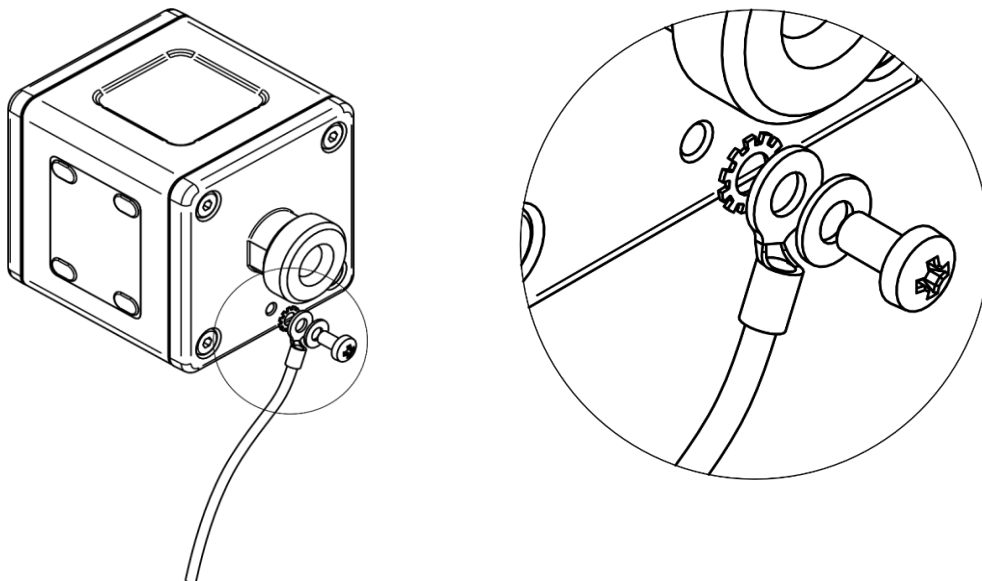

## 8.2 Pin assignment

### 8.2.1 External connection with electrical connector M12x1 4-pin for options C3T0 / Exx0 and Pxx0

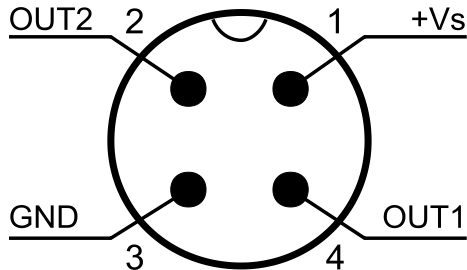

### 8.2.2 Connection Exx0 / Pxx0 sensor

For the remote versions Pxx0 (PVC cable) and Exx0 (ETFE cable), the sensor and transmitter are delivered ex works with the cable connected.

The on-site installation may require dismantling the cable and reconnecting it later.

	<p>Note: In principle, the cable can be shortened by the user on the transmitter side and connected to the transmitter again after appropriate assembly.</p>
<p>Note</p>	

	<p>A customer extension of the connection cable is not recommended because of the necessary continuous shielding and leads to malfunction of the device. The cable permanently connected to the sensor must not be disassembled.</p>
<p>Caution</p>	

	<p>Attention! Only sensors and transmitters with an identical serial number may be operated together, because the factory calibration is only valid in this case. If sensors and transmitters with different serial numbers are operated together, this will lead to incorrect flow measurement values.</p>
<p>Caution</p>	

## Wiring diagram Transmitter

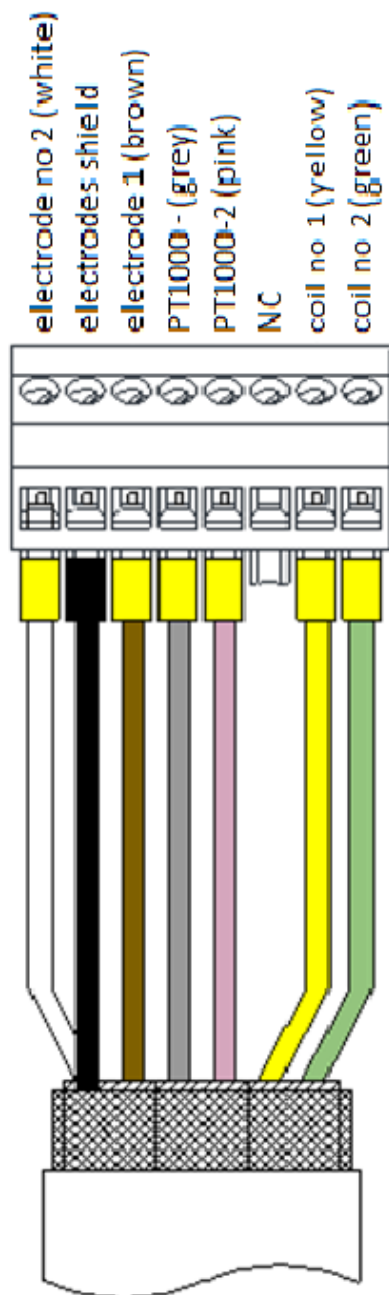

## Termination Connection cable (PVC and ETFE cable)

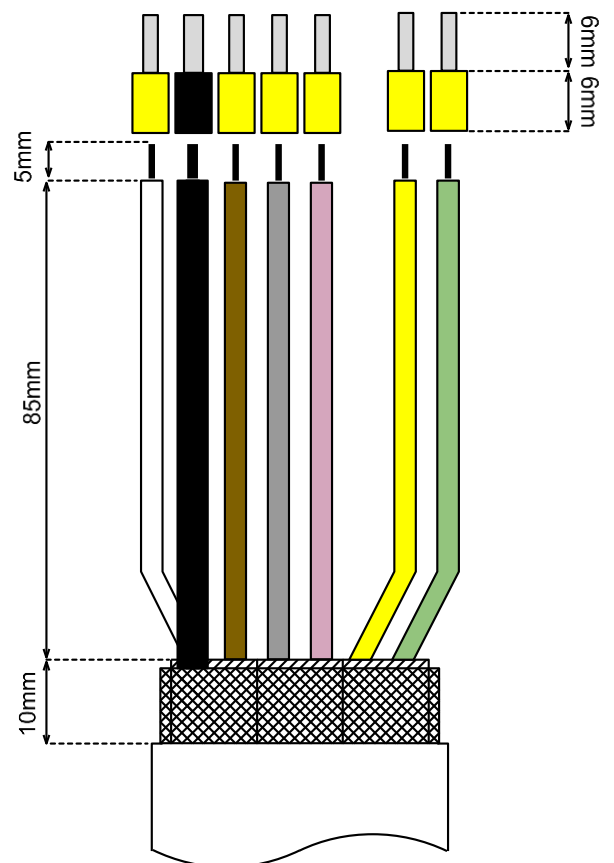

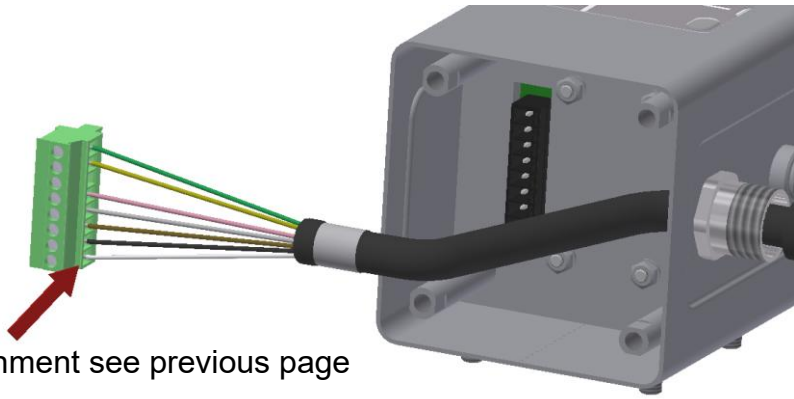

Pin assignment see previous page

Insert pre-assembled cable through the cable gland and connect to the connector strip

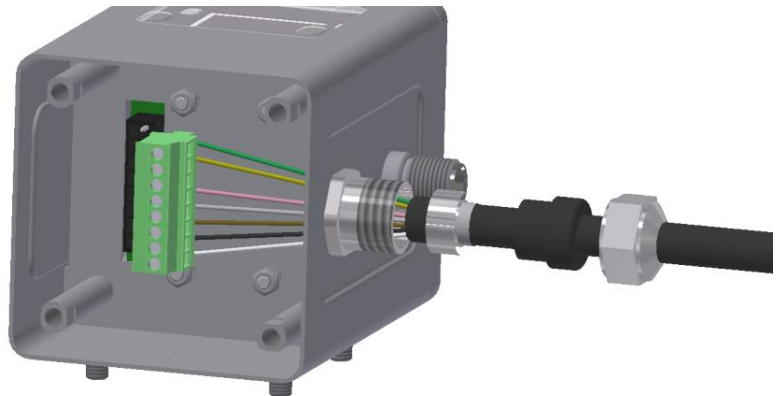
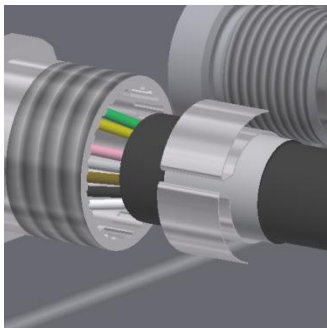

Pull back the cable and put the contact spring on the outer shield

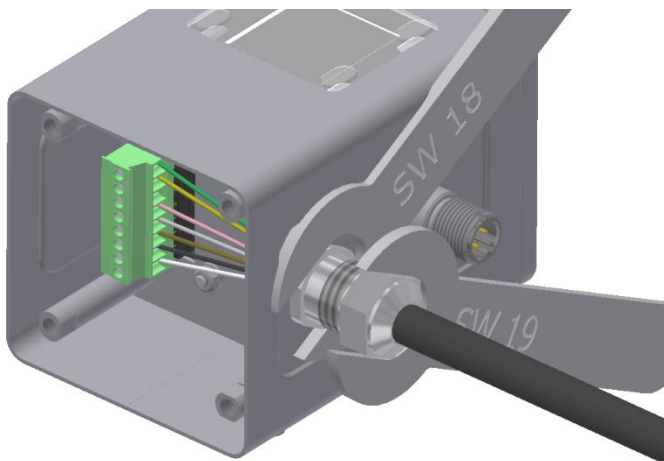

Push the cable into the cable gland, insert the plug connector and tighten the hexagon nut of the cable gland with SK key SW 19 and lock with SW 18

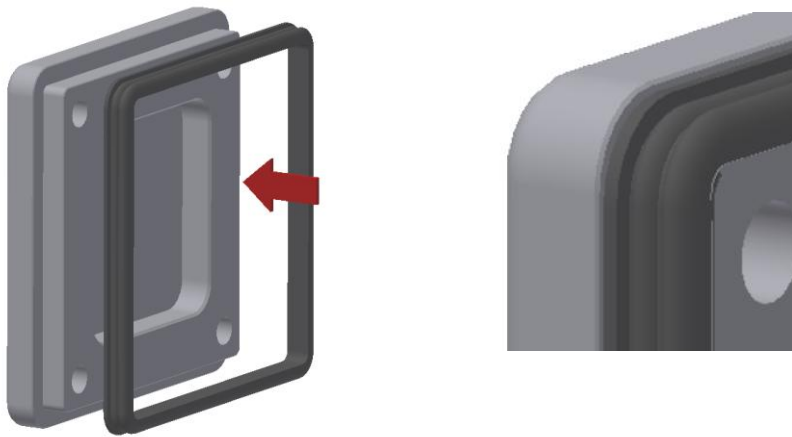

Insert gasket, make sure gasket is seated correctly

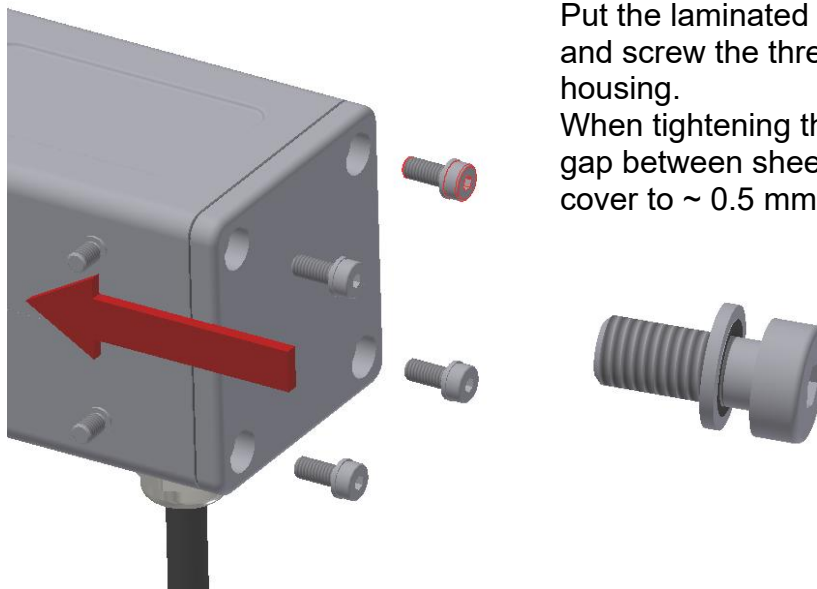

Put the laminated seal disc on the screw and screw the threaded connection in the housing.  
When tightening the screws, reduce the gap between sheet metal housing and the cover to ~ 0.5 mm

### 8.3 Connection example outputs:

OUT2: analogue output 4-20 mA

OUT1: analogue output 0-10 V

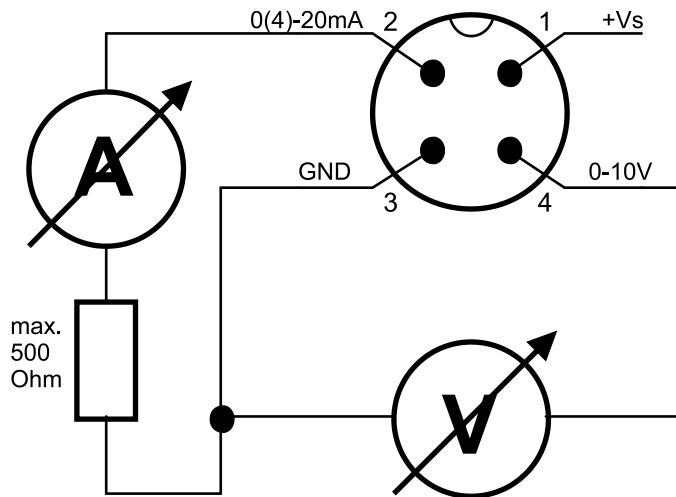

Configurable output functions:

Out 1	Out 2
analogue output 4-20 mA	analogue output 4-20 mA
analogue output 0-20 mA	analogue output 0-20 mA
analogue output 2-10 V	analogue output 2-10 V
analogue output 0-10 V	analogue output 0-10 V
alarm output	alarm output
pulse output	pulse output
frequency output	frequency output
communication mode KofiCom	
communication mode IO Link	
control input	
control input dosing function	dosing output

## 9. Operation and menu structure

---

See "User Manual Supplement for U-PACE Electronics"

### **Important note for MIM devices with software REV190320:**

 <p>Note</p>	<p>If Output 1 is to be operated as a current output, the output must be switched from IO-LINK (device delivery state) to current output before electrically connecting the current loop. Failure to do so will block access to the menu function and make the device unconfigurable.</p>
---	---

## 10. Status

The electromagnetic flowmeter can detect and display various device or application errors.

If there is a status or error message, the STATUS symbol in the display alternately flashes orange / red. To call up the status / error information, the status key must be pressed, then the status window that appears then lists all the messages that have accumulated up to this point in time. By pressing the  $\cdot \leftarrow \leftarrow \leftarrow \cdot$  key, the user confirms the knowledge of the displayed errors, the status memory is cleared and the status window is closed. If one of the displayed errors persists, it will be reported again by flashing the status icon.

The following status / error messages are generated:

Display text	Description	Debugging
<i>Empty Pipe</i>	Measuring tube is not completely filled with medium or medium with too low conductivity is used.	Check the filling of the measuring circuit or conductivity of the medium (> 20 $\mu\text{s} / \text{cm}$ )
<i>Temp Sens Error</i>	Error in the temperature measuring circuit	Repair by KOBOLD Service necessary
<i>Meas saturated</i>	Flow measuring circuit overdriven	Reduce flow rate
<i>No Subslave</i>	Internal hardware error	Repair by KOBOLD Service necessary
<i>Simulation</i>	Simulation function active	-

## 11. IO-Link function

As of firmware version REV190320, the MIM flowmeter has an IO-Link communication interface as standard. Process and diagnostic data can be accessed directly via this interface and the device can be parameterized.

Output 1 is factory configured for IO-Link function. If the IO-Link communication mode is active, the "IOLINK" symbol in the status display for the outputs is displayed in green. The setup menu remains locked when the IOLINK mode is active and is inaccessible.

To ensure that the IO-Link device can be operated correctly on the connected IO-Link master, it is necessary to install the device description file matching the device.

The device description files (IODD) are available in the IODDfinder database under [ioddfinder.io-link.com](http://ioddfinder.io-link.com). There may be different IODD versions available for devices of the same type. To select the correct IODD, the device ID can either be read out via the connected IO-Link master or, alternatively, identification can be made using the device's firmware identifier.

The IODD assignment can be found in the following table.

Firmware ID	Product type	Device-ID [hex]	Device-ID [dec]	Remarks
V01.11_Rxxxxxx	MIM Compact up to 1 inch	0x010600	67072	-
	MIM Compact 2 inch	0x010700	67328	-
	MIM Remote up to 1 inch	0x010800	67584	-
	MIM Remote 2 inch	0x010900	67840	-
From V01.11_R230615	MIM-XXXXXXXXXXXX	0x010B00	68352	A common IODD for all MIM devices
From V02.11_R231018	MIM-XXXXXXXXXC3TX	0x010D00	68864	

How to download the correct IODD:

- Read out the firmware ID of the device from the INFO menu
- Find out the device ID (decimal) from the table above according to the firmware identification and the product type
- In the IODD finder, identify the correct IODD using the Device ID column and download the associated ZIP file using the download button.

If the device is operated on an IO-Link master with port class A, only a maximum output current of 50 mA may be drawn from output 2 (OUT2) (current or binary output), otherwise the IO-Link master will be overloaded and it can cause malfunctions.

## 11.1 Specification

Manufacturer	ID 1105 (decimal), 0x0451 (hex)
Manufacturer name	Kobold Messring GmbH
IO-Link specification	V1.1
Bitrate	COM3
Minimum cycle time	1.1 ms
SIO mode	yes (OUT1 in configuration IO-Link)
Block parameterisation	yes
Ready for operation	10 sec.
Max. cable length	20 m
IO-Link master port class	A

## 12. Technical Information

---

Operating instructions, data sheet, approvals and further information via the QR code on the device or via [www.kobold.com](http://www.kobold.com)

## 13. Order Codes

---

Operating instructions, data sheet, approvals and further information via the QR code on the device or via [www.kobold.com](http://www.kobold.com)

## 14. Dimensions

---

Operating instructions, data sheet, approvals and further information via the QR code on the device or via [www.kobold.com](http://www.kobold.com)

## 15. Disposal

---

See “General Safety Instructions” - via the QR code on the device or via [www.kobold.com](http://www.kobold.com)

## 16. Appendix

The specifications and parameters for the MIM devices with IO-Link function are available on the website

<https://ioddfinder.io-link.com>

available. The necessary information is available here

- Process data structure
- Diagnostic functions
- IO-Link commands
- ISDU parameters

The following table provides links to the different versions

Firmware ID	Device-ID [hex]	Device-ID [dec]	Link
V01.11_Rxxxxxx	0x010600	67072	<a href="https://ioddfinder.io-link.com/productvariants/search/19568">https://ioddfinder.io-link.com/productvariants/search/19568</a>
	0x010700	67328	<a href="https://ioddfinder.io-link.com/productvariants/search/19569">https://ioddfinder.io-link.com/productvariants/search/19569</a>
	0x010800	67584	<a href="https://ioddfinder.io-link.com/productvariants/search/19570">https://ioddfinder.io-link.com/productvariants/search/19570</a>
	0x010900	67840	<a href="https://ioddfinder.io-link.com/productvariants/search/19571">https://ioddfinder.io-link.com/productvariants/search/19571</a>
From V01.11_R230615	0x010B00	68352	<a href="https://ioddfinder.io-link.com/productvariants/search/39456">https://ioddfinder.io-link.com/productvariants/search/39456</a>
From V02.11_R231018	0x010D00	68864	<a href="https://ioddfinder.io-link.com/productvariants/search/43585">https://ioddfinder.io-link.com/productvariants/search/43585</a>

Parameters relating to the measured values flow, temperature or volume must be entered in the basic units and, if necessary, converted beforehand. The basic units are:

Flow: **L/min**

Temperature: **°C**

Volume: **liters**

**Units conversion table**

Category: <b>Flow</b>		
Unit	description	conversion
L/m	Liters per minute (basic unit)	-
L/h	Liters per hour	1 L/h = 0.0167 L/m
mL/m	Milliliters per minute	1 mL/m = 0.001 L/m
m <sup>3</sup> /h	Cubic meters per hour	1 m <sup>3</sup> /h = 16.667 L/m
gal/m	US gallons per minute	1 gal/m = 3.7854 L/m
gal/h	US gallons per hour	1 gal/h = 0.06309 L/m
galk/m	UK gallons per minute	1 galk/m = 4.54609 L/m
galk/h	UK gallons per hour	1 galk/h = 0.07577 L/m
L/s	Liters per second	1 L/s = 60 L/m
mL/s	Milliliters per second	1 mL/s = 0.0000167 L/m
USER	user unit	1 user unit = USER * L/m





Category: <b>Temperature</b>		
Unit	description	conversion
°C	degree Celsius (basic unit)	-
°F	degree Fahrenheit	$x \text{ °C} = (32 + x * 1,8) \text{ °F}$
USER	user unit	1 user unit = USER * °C

Category: <b>Volume</b>		
Unit	description	conversion
L	Liters (basic unit)	-
mL	Milliliters	1 mL = 0.001 L
m <sup>3</sup>	Cubik meters	1 m <sup>3</sup> = 1000 L
galUS	US gallons	1 galUS = 3.7854 L
galUK	UK gallons	1 galk = 4.54609 L
barrel	Barrel (US)	1 barrel = 158.99 L
USER	user unit	1 user unit = USER * L

 <p>Note</p>	<p>If a measured value is invalid due to an error status (NAN), the corresponding process value is output with the value "0". In this case, the device status and the events must also be taken into account.</p>
---	---

# 1. Manufacturer's declaration

For IO-Link Device-ID no. 67072, 67328, 67548 and 67840:

			
<b>MANUFACTURER'S DECLARATION OF CONFORMITY</b>			
<b>We:</b>			
Kobold Messring GmbH Nordring 22-24 65719 Hofheim Germany			
 <b>declare under our own responsibility that the product(s):</b>			
MIM-XXXXXXXXXX (IO-Link Device)			
 <b>to which this declaration refers conform to:</b>			
<input checked="" type="checkbox"/> IO-Link Interface and System Specification, V1.1, July 2013 (NOTE 1, 2)			
<input checked="" type="checkbox"/> IO Device Description, V1.1, August 2011			
 <b>The conformity tests are documented in the test report(s):</b>			
IO-Link_Device_TestReport_MIM_20230414.pdf			
 <b>Issued at Hofheim, 20.06.2023</b>			
<b>Authorized signatory</b>			
<b>Name:</b>	Hans Volz	<b>Name:</b>	Manfred Wenzel
<b>Title:</b>	General Manager	<b>Title:</b>	Proxy Holder
<b>Signature:</b>		<b>Signature:</b>	
Reproduction and all distribution without written authorization prohibited			
NOTE 1 Relevant Test specification is V1.1, July 2014		MD-Version: V1.1.2	
NOTE 2 Additional validity in Corrigendum Package 2015			

For IO-Link Device-ID no. 68352:

<https://ioddfinder.io-link.com/productvariants/search/39456>

For IO-Link Device-ID no. 68864:

<https://ioddfinder.io-link.com/productvariants/search/43585>

## 2. Confirmation for contact with drinking water

**Konformitätsbestätigung für den Kontakt mit Trinkwasser**  
*Confirmation for contact with drinking water*

**TrinkwV (Germany)**  
**WRAS-BS 6920-1:2000 (UK)**

**Kobold Messring GmbH, Hofheim-Ts., bestätigt hiermit für die Materialien und Gegenstände, die bei bestimmungsgemäßem Gebrauch in Kontakt mit Trinkwasser kommen können, die Konformität der trinkwasserhygienischen Eignung.**

*Kobold Messring GmbH, Hofheim-Ts., hereby confirms the conformity of the drinking water hygienic suitability for the materials and objects that can come into contact with drinking water when used as intended.*

**zusammengesetztes Produkt**    *composite product*

**Die Aktualität der Konformitätsbestätigungen der Ausgangsstoffe und der dazugehörige Wareneingang wurden überprüft.**  
*The up-to-dateness of the conformity confirmations of the starting materials and the associated goods receipt were checked.*

Gerätetyp	MIM	Magnetisch induktiver Durchflussmesser
model	MIM	Magnetic inductive flow meter

### Ausgangsstoffe *raw materials*

Pos. <i>item</i>	Benennung <i>type</i>	Werkstoff <i>material</i>	Materialgruppe <i>material group</i>	Bemerkungen <i>remarks</i>
01	Anschlussfittings <i>connection fittings</i>	1.4404	Metall <i>metal</i>	
02	Elektroden <i>electrodes</i>	1.4404	Metall <i>metal</i>	
03	Temperaturfühler <i>temperature sensor</i>	1.4404	Metall <i>metal</i>	
04	Isolierteil <i>isolating part</i>	PEEK	Kunststoff <i>plastic</i>	
05	Dichtungen <i>seals</i>	EPDM	Elastomer <i>elastomer</i>	
06				
07				
08				
09				
10				

10.02.2022

**ppa Manfred Wenzel**

Datum *date*

Unterschrift  
*signature*

Leiter Compliance  
*compliance manager*

Dieses EDV-Dokument ist ohne persönliche Unterschrift gültig! *This electronic document is valid without any signature!*  
 QS03-09 Änd. 02/22

### 3. EU Declaration of Conformance

---

We, KOBOLD Messring GmbH, Nordring 22-24, 65719 Hofheim, Germany, declare under our sole responsibility that the product:

**Electromagnetic Flowmeter**

**Model: MIM -1xxxxxxxxxx**

to which this declaration relates is in conformity with the following EU directives stated below:

**2014/30/EU**

**EMC Directive**

**2011/65/EU**

**RoHS (category 9)**

**2015/863/EU**

**Delegated Directive (RoHS III)**

Also, the following standards are fulfilled:

**EN IEC 61326-1:2021**

Electrical equipment for measurement, control and laboratory use – EMC requirements - Part 1: General requirements, Industrial area (measurement of immunity to RF fields up to 2.7 GHz)

**EN 60529:2014**

Degrees of protection provided by enclosures (IP Code)

**DIN EN IEC 63000:2018**

Technical documentation for the assessment of electrical and electronic products with respect to the restriction of hazardous substances

Hofheim, 06 Feb. 2025



H. Volz  
General Manager



J. Burke  
Compliance Manager

## 4. UK Declaration of Conformity

---

We, KOBOLD Messring GmbH, Nordring 22-24, 65719 Hofheim, Germany, declare under our sole responsibility that the product:

**Electromagnetic Flowmeter**

**Model: MIM -1xxxxxxxxxx**

to which this declaration relates is in conformity with the following UK directives stated below:

**S.I. 2016/1091          Electromagnetic Compatibility Regulations 2016**

**S.I. 2012/3032          The Restriction of the Use of Certain Hazardous Substances in Electrical and Electronic Equipment Regulations 2012**

Also, the following standards are fulfilled:

**BS EN IEC 61326-1:2021**

Electrical equipment for measurement, control and laboratory use. EMC requirements. General requirements, Industrial area (measurement of immunity to RF fields up to 2.7 GHz)

**BS EN 60529:1992+A2:2013**

Degrees of protection provided by enclosures (IP-Code)

**BS EN IEC 63000:2018**

Technical documentation for the assessment of electrical and electronic products with respect to the restriction of hazardous substances.

Hofheim, 06 Feb. 2025

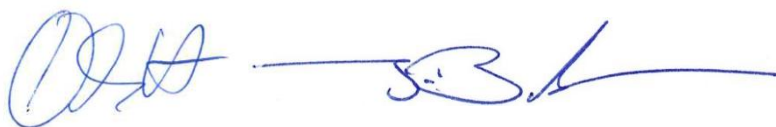

H. Volz  
General Manager

J. Burke  
Compliance Manager