



# Variable-Area Flowmeter

K09

## Operating Instructions



Please read the instructions carefully and store them in a safe place

## Contents

Operating Instructions .....	1
Introduction .....	4
I. Shipping and Storage; Product Inspection .....	4
II. Warranty .....	4
III. Maintenance, Repair and Hazardous Substances.....	4
IV. Disposal .....	4
V. Supplementary Operating Instructions.....	4
VI. Operating Manual of Explosion-Proof Flowmeters .....	4
1. Steps Prior to Operation .....	5
2. Safety Advisories.....	6
2.1 Installation, Commissioning, Operating Personnel.....	6
2.2 Hazard Warnings .....	6
2.3 Proper Use of the Device.....	7
2.4 Packaging, Storage and Transport.....	7
2.4.1 Disposal.....	8
2.5 Returning your Flowmeter for Servicing or Calibration.....	8
3. Identification .....	9
3.1 Designation / Rating Plate .....	9
3.2 K09 Applications.....	10
3.2.1 Standard K09 Device .....	10
3.2.2 K09-..V / N differential pressure regulator .....	10
4. Operational mode and system design K09.....	11
4.1 Measurement Principle – Variable area Flowmeter .....	11
4.2 Measuring principle for K09- V / N Differential pressure regulator.....	11
4.3 K09-..V / N system design.....	11
5. Key values .....	12
5.1 Measured variable .....	12
5.2 Measuring ranges.....	12
5.3 Electrical output (option) .....	13
5.3.1 Add-on limit switches Type RC 10/15-14-XX, Manufacturer Pepperl & Fuchs.....	13
5.3.2 Add-on limit switches Type N7R**A, Manufacturer ifm electronic .....	13
5.4 Measuring accuracy .....	13
6. Conditions of use.....	14
6.1 Safe operation .....	14
6.1.1 General conditions for safe operation.....	14
6.1.2 Requirements for installation in all environments .....	14
6.1.3 Requirements for installation dust environments .....	14
6.1.4 Mounting and commissioning .....	15
6.2 Ambient conditions.....	15
6.2.1 Ambient temperature ranges .....	15
6.2.2 Storage temperature.....	15
6.2.3 Climatic category .....	15
6.2.4 Degree of protection.....	15
6.2.5 Shock resistance/vibration resistance .....	15
6.2.6 Electromagnetic compatibility.....	15

6.3	Fluid conditions.....	15
6.3.1	Fluid temperature ranges .....	15
6.3.2	Fluid pressure limit .....	16
6.3.3	Inlet and outlet sections .....	16
6.3.4	Physical state.....	16
6.3.5	Pressure for gas measurement.....	16
6.3.6	Pressure loss .....	16
7.	Construction details .....	17
7.1	Design/dimensions K09 .....	17
7.2	Design / Dimensions / Commissioning V / N (option diff. pressure regulator) .....	17
7.2.1	Dimension drawing K09-N as regulator c/w constant outlet pressure .....	18
7.2.2	Dimension drawing K09-V as regulator c/w constant inlet pressure.....	18
7.3	Weight: .....	18
7.4	Materials:.....	19
7.5	Process connection:.....	19
8.	Electrical connection for limit switch (option) .....	20
9.	Indicator unit.....	20
10.	Use in hazardous areas.....	21
10.1	General Information on Ex-Protection.....	21
10.2	Atmospheric Conditions.....	22
10.3	Electrostatic charge of non-conductive parts.....	22
10.3.1	Grounding.....	22
10.4	Mechanical strength.....	23
10.5	Without electrical equipment .....	23
10.6	With limit switch.....	23
11.	CE marking .....	24
11.1	Standards and directives.....	24
12.	Available accessories.....	24
13.	Order information .....	24
14.	Maintenance .....	24
14.1	Cleaning.....	24
14.2	Replacing the measuring cone.....	25
14.2.1	Removal:.....	25
14.2.2	Installation:.....	25
14.2.3	Depiction of the dis- and reassembly .....	25
15.	Returning devices for repair and service.....	26
16.	Decontamination certificate for device cleaning .....	27
17.	Model Code.....	28
18.	Declaration of Conformity.....	30
18.1	EU Declaration of Conformity.....	30

## Introduction

### I. Shipping and Storage; Product Inspection

#### Shipping and Storage

The device is to be safeguarded against moisture, dirt (especially the meters internal), impact and damage. The storage temperature limits are to be observed. Depending on the device size the area flowmeters float may be secured. This transport protection must be removed before the device is installed.

#### Product inspection

Upon receipt of the product, the consignment should be checked for completeness. The data of the device have to be compared with the packing slip and the order documents

Notify us of any shipping damage immediately upon receipt of the product. Any damage claim received at a later time will not be honoured.

### II. Warranty

Your flow meter was manufactured in accordance with the highest quality standards and was thoroughly tested prior to shipment. However, in the event any problem arises with your device, we will be happy to resolve the problem for you as quickly as possible under the terms of the warranty which can be found in the terms and conditions of delivery. Your warranty will only be honoured if the device was installed and operated in accordance with the instructions for your device. Any mounting, commissioning and/or maintenance work is to be carried out by qualified and authorized technicians only.

### III. Maintenance, Repair and Hazardous Substances

When used in the intended manner no special maintenance is required. However, the flowmeter should be checked within the context of routine maintenance of the facility and the pipelines. Should a repair, calibration or maintenance become necessary, be sure to clean the device thoroughly and follow the steps in section 2.5 "Returning your Flowmeter for Servicing or Calibration" on page 8 before returning the device to Heinrichs Messtechnik. The operator is liable for any substance removal or personal damage costs arising from inadequate cleaning of a device sent for repair.

### IV. Disposal

Observe the regulations applicable to disposal in the country of installation!

### V. Supplementary Operating Instructions

Supplement operating manuals are available for special features, interfaces and operations relating to your device, request your copy from our service department.

### VI. Operating Manual of Explosion-Proof Flowmeters

For installation of the flowmeter within hazardous areas read the operation manual of explosion-proof flowmeters. It contains all the EX-relevant information for your flowmeter.

For installation in potentially explosive areas, you also need the type test certificate for the installed switch. If you do not have this, contact Heinrichs Messtechnik GmbH or download it from the manufacturer's website.



#### Warning

Only devices designated as EX-certified on their rating plates may be used in areas of potentially explosive atmospheres!

The use of standard equipment in EX-hazardous areas is strictly prohibited.

---

## 1. Steps Prior to Operation



These montage and operating instructions are provided to help aid in the correct installation as well as for the operation and maintenance of the meter. It is essential that you read these operating instructions before installing and operating the device. The device is to be installed and serviced by a qualified technician only. Special designs and applications are not included in this manual.

Downloading of the present document from our web site [www.heinrichs.eu](http://www.heinrichs.eu) and printing out this document is allowed only for the purposes of using our mass flowmeters. All rights reserved. No instructions, wiring diagrams, and/or supplied software, or any portion thereof, may be produced, stored, in a retrieval system or transmitted by any means, electronic, mechanical, photocopying or otherwise, without the prior written permission of Heinrichs Messtechnik GmbH.

Although the materials in the present document were prepared with extreme care, errors cannot be ruled out. Hence, neither the company, the programmer nor the author can be held legally or otherwise responsible for any erroneous information and/or any loss or damage arising from the use of the information enclosed.

Heinrichs Messtechnik GmbH extends no express or implied warranty concerning the applicability of the present document for any purpose other than that described.

We plan to optimize and improve the products described and in so doing will incorporate not only our own ideas but also, and in particular, any suggestions for improvement made by our customers. If you feel that there is any way in which our products could be improved, please send your suggestions to the following address:

Heinrichs Messtechnik GmbH

HM-EE (R&D Department)  
Robert-Perthel-Strasse 9  
D-50739 Cologne  
Germany

or:

 via fax : +49 (221) 49708-178

 via email: [info@heinrichs.eu](mailto:info@heinrichs.eu)



### Note

We reserve the right to change the technical data in this manual in the light of any technical progress that might be made.

For updates regarding this product, visit our website at [www.heinrichs.eu](http://www.heinrichs.eu), where you will also find contact information for the Heinrichs Messtechnik distributor nearest you. For information regarding our own sales operations, contact us at [info@heinrichs.eu](mailto:info@heinrichs.eu).

## 2. Safety Advisories

### 2.1 Installation, Commissioning, Operating Personnel

The present document contains the information that you need in order to operate the product described herein properly. This document is intended for use by qualified personnel. This means personnel who are qualified to operate the device described herein safely, including

- electronics engineers,
- electrical engineers, or
- service technicians

who are conversant with the safety regulations pertaining to the use of electrical and automated technical devices and with the applicable laws and regulations in their own country.

Assembly, installation, commissioning and maintenance in potentially explosive areas may only be carried out by personnel trained in "explosion protection". Only trained specialists authorized by the system operator may perform electrical installations, commissioning, maintenance work and operation. This personnel must have read and understood the contents of this operating instructions before working with the device.

In general, the provisions and regulations applicable in your country must be observed.

Used as intended, the device requires no special maintenance. However, the flow meter must also be inspected as part of the routine operational maintenance of the system. Particular attention must be paid to contamination, corrosion, mechanical wear and tightness. We recommend an annual review cycle. Also see Chapter 14 Maintenance





#### Warning!

The devices described in this manual are to be installed and serviced only by qualified technical personnel such as a qualified Heinrichs Messtechnik electronics engineers or service technicians.

Should repair or maintenance by the manufacturer be required, before returning the device to Heinrichs Messtechnik the device must be thoroughly cleaned, following the steps in Chapter 15 "Returning devices for repair and service". Costs incurred as a result of inadequate cleaning of the device (disposal or personal injury) shall be billed to the customer.

Heinrichs Messtechnik GmbH accepts no liability for any loss or damage of any kind arising from improper operation of any product, improper handling or use of any replacement part, or from external electrical or mechanical effects, overvoltage or lightning. Any such improper operation, use or handling shall automatically invalidate the warranty for the product concerned.

In the event a problem arises with your device, or if you need assistance in diagnosing a problem with your device, please contact us at one of the following numbers to arrange to have your device repaired:

	Phone:	+49 221 49708-0
	Fax:	+49 221 49708-178
	Internet:	<a href="http://www.heinrichs.eu">www.heinrichs.eu</a>
	email:	<a href="mailto:info@heinrichs.eu">info@heinrichs.eu</a>

Our customer service is at your disposal for the coordination and assistance of any required diagnostic and repair measures.

### 2.2 Hazard Warnings

The purpose of the hazard warnings listed below is to ensure that device operators and maintenance personnel are not injured and that the flow meter and any devices connected to it are not damaged.

The safety advisories and hazard warnings in the present document that aim to avoid placing operators and maintenance personnel at risk and to avoid material damage are prioritized using the terms listed below, which are defined as follows in regard to these instructions herein and the advisories pertaining to the device itself:



Warning

means that failure to take the prescribed precautions could result in injury, substantial material damage or even death. Always comply to these warnings and proceed with caution.



Caution

means that failure to take the prescribed precaution could result in material damage or destruction of the device. We advise always to abide to these instructions!



Note

means that the accompanying text contains important information about the product, handling the product or about a section of the documentation that is of particular importance.

### 2.3 Proper Use of the Device

The variable area flow meter is intended for the sole use of direct and continuous volume flow measurement of liquids and gases.

To ensure safety for people and the environment adhere to the installation and operational instructions and warning in this manual.



Warning

The operator is responsible for ensuring that the material used in the sensor and housing are suitable and that such material meets the requirements for the process medium and the ambient site conditions.

The manufacturer accepts no responsibility for the selection of unsuitably materials.



Warning

Before using the meter with corrosive or abrasive media, the operator must check the suitability of all materials that come into contact with the media. In the case of special media, including cleaning media, we will be happy to help you check the corrosion resistance of materials. However, since small changes in the process temperature, concentration or the degree of contamination can result in changes in the corrosion resistance, the full responsibility must remain with the operator.



Caution

To ensure the device performs correctly and safely, it must be shipped, stored, set up, mounted, operated and maintained correctly.

### 2.4 Packaging, Storage and Transport

Take care whilst unpacking the device to avoid damaging it. With the help of the delivery note enclosed in the packaging, check whether all technically relevant data coincide with your requirements.

Storage and installation must be performed in a clean and dry room to avoid – especially of the interior of the fitting – contamination.

The ambient temperature limiting values are to be adhered to.

When transporting the device to a remote mounting location, we recommend the reuse of the factory-issued packaging.

#### 2.4.1 Disposal

##### Packaging

- Avoid environmental damage caused by media-contaminated parts
- Dispose of devices and packaging in an environmentally friendly manner
- Comply with applicable national and international disposal and environmental regulations

##### Batteries

Your device contains no batteries or accumulators.

##### Electrical and Electronic devices

Old electrical and electronic equipment must be disposed of in the correct manner. Please observe the regulations applicable to disposal in the country of installation.



## 2.5 Returning your Flowmeter for Servicing or Calibration

Before sending your flowmeter back to us, for servicing or calibration, make sure it is completely clean. Any residues of substances that could be hazardous to the environment or human health are to be removed from all crevices, recesses, gaskets, and cavities of the housing before the device is shipped.



##### Warning

The operator is liable for any loss or damage of any kind, including personal injury, decontamination measures, removal operations and the like that are attributable to inadequate cleaning of the device.

Any device sent in for servicing is to be accompanied by a Decontamination certificate for device cleaning, a template of which is provided in section 16 on page 27.

When returned, the device is to be accompanied by a document describing the problems encountered. Please include in this document the name of a contact person whom our technical service department can contact to enable us to repair your device as expeditiously as possible and minimize the repair costs.

### 3. Identification

Manufacturer: Heinrichs Messtechnik GmbH  
 Robert-Perthel-Strasse 9  
 D-50739 Cologne  
 Germany

 Phone: +49 221 49708-0  
 Fax: +49 221 49708-178  
 Internet: [www.heinrichs.eu](http://www.heinrichs.eu)  
 Email: [info@heinrichs.eu](mailto:info@heinrichs.eu)

Contact Information Importer

Product type: Low flow - variable area flow meter.  
 Product name: K09  
 File name: DRAFT\_VIL\_K09\_BA\_23.01\_EN  
 Version: 23.01  
 Publish date 09.08.2024

#### 3.1 Designation / Rating Plate

The device and its specifications are presented as a model-code on the rating plate. The model-code consists of the prefix "K09" followed by an alpha-numerical code.

Refer to section 17 Model Code on page 17 for a description of each position.

K09 Rating plate examples



Image 1: Example of a standard K09 rating plate

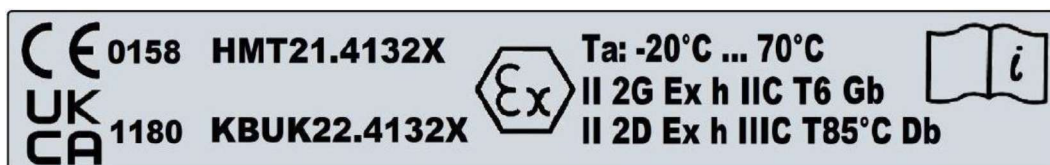

Image 2: Example of a supplementary K09 Ex-marking rating plate

## 3.2 K09 Applications

### 3.2.1 Standard K09 Device

The flow meter is suitable for the measurement of the flow of liquid and gaseous products in pipes. It displays the current flow in volume or mass per unit time.

Typical applications:

Measuring the flow of liquid and gaseous products in pipes as well as dosing, superimposing, monitoring, regulating and the controlling of them.

### 3.2.2 K09-.V / N differential pressure regulator

The flow meter can be used for stabilizing a constant flow of liquid and gaseous products in pipes. The flow is kept constant regardless of pressure changes during product inflow for type K09-.N or of a pressure change during product outflow for type K09-.V.

Typical applications: Constant dosing, level measurement in open and closed vessels, N<sub>2</sub> superposition of combustible media



#### Warning

The devices should be used with the greatest possible caution when measuring potentially hazardous liquids and (especially) gases. Precautionary measures must be taken to protect personnel and equipment from any potential danger or damage resulting from glass-tube breakage. The plant operator carries full responsibility for the use of the devices.

Where possible, we recommend the use of full metal devices such as type KDS.

---



#### Warning

Only devices marked as Ex-devices on their rating plates may be used in EX hazardous locations. Standard equipment is not permitted for installation and operation in EX hazardous locations.

For installation within hazardous areas read the Ex-supplementary manual available at [www.heinrichs.eu](http://www.heinrichs.eu). It contains all EX-relevant parameters for the K09 flow-meter.

---

## 4. Operational mode and system design K09

### 4.1 Measurement Principle – Variable area Flowmeter

The measuring instrument composes of a float and a conical glass tube (M)

A medium flows from the bottom to the top through the measuring ring, lifting the float in the process until the buoyancy force (A) and the weight of the float ( $G_s$ ) establish equilibrium. As the height of the float varies, an annular clearance (S) proportional to the flow appears between the float and the measuring tube. The height of the float (K) in the measuring tube serves as the actual rate of the flow. The flow rate is read directly from the scale.

The readings obtained apply solely to the medium for which the device has been calibrated or for a medium with the same density and viscosity as the calibration medium.

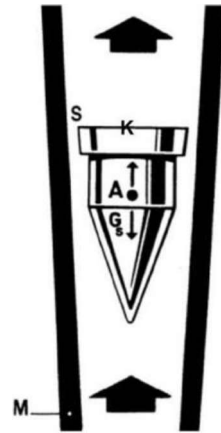

### 4.2 Measuring principle for K09- V / N Differential pressure regulator

The diaphragm of the controller is in a state of equilibrium when the pressure conditions are the same on both sides. The pressure on the inlet side is determined by the pressure of the product; the pressure on the outlet side is determined by the pressure drop of the setting valve of the flow meter.

If either the inlet or outlet pressure changes, the change in pressure is compensated by the built-in diaphragm valve - thus maintaining a constant set flow rate.



#### Caution!

The regulator can only regulate inlet (V Version) or outlet (N Version) pressure fluctuations. Steady pressure conditions must prevail on each side of the regulator.

### 4.3 K09-..V / N system design

The unit consists of a K09 variable-area flow meter, equipped with a diaphragm differential pressure flow regulator. The variable-area flow meter consists of a device fitting with an integrated measuring tube made of glass that contains a vertically movable float and the valve for setting the flow rate.

The differential pressure flow controller is made of stainless steel and consists of a diaphragm made of Viton or PTFE and a compensating valve made of stainless steel.

For gaseous products, there are two versions available:

- K09-...V for a constant inlet pressure and a variable outlet pressure
- K09-...N for a constant outlet pressure and a variable inlet pressure

For liquids, both versions can be used; however, the K09-...V version should be favoured.



## 5. Key values

### 5.1 Measured variable

Volume flow

### 5.2 Measuring ranges

Measuring ranges (lower-range and upper-range values)

Measuring span water 20 °C:

Smallest measuring range: 0.02-0.25 l/h water

Largest measuring range: 10-100 l/h water

Measuring span air 20 °C, 1.013 bar abs.:

Smallest measuring range: 2-20 NI/h air

Largest measuring range: 300-3000 NI/h air

Measuring /regulating range for K09-..V / N (Differential pressure regulator)

Span: 10-100 %

#### Measuring range table

All measurement range values with fully open valve

Measuring ranges water 20 °C					Measuring ranges air 1.013 bar abs., 20 °C				
Float SS 1.4401 (316L) / glass					Float SS 1.4401 (316L) / glass				
Range N°	Water l/h	Float material	Valve seat ø (mm)	Press. loss (mbar)	Range N°	air l/h	Float material	Valve seat ø (mm)	Press. loss (mbar)
91**	0,02-0,25	glass	2.8	2	88**	2-20	glass	2.8	1
92**	0,08-0,7	glass	2.8	3	89**	4-40	glass	2.8	2
79	0,1-1	1.4401	2.8	2	70	5-50	1.4401	2.8	1
80	0,25-2,5	1.4401	2.8	3	71	10-100	1.4401	2.8	2
81	1,0-10	1.4401	2.8	3	90**	12-120	glass	2.8	2
82	1,5-16	1.4401	2.8	5	72	25-250	1.4401	2.8	2
83	2,5-25	1.4401	2.8	5	73	30-350	1.4401	2.8	2
84	4-40	1.4401	2.8	5	74	50-450	1.4401	2.8	3
85	5-65	1.4401	2.8	5	75	60-800	1.4401	2.8	3
86	6-63	1.4401	2.8	6	76*	120-1200	1.4401	2.8	3
87	10-100	1.4401	2.8	6	77*	200-2000	1.4401	2.8	3
					78	300-3000	1.4401	2.8	3

\* Limited adjustment range of the limit-switch / switch can only be adjusted as min. contact.

\*\* No electronic limit switches possible

### 5.3 Electrical output (option)

1 inductive limit switch, mono- or bi-stable

#### 5.3.1 Add-on limit switches Type RC 10/15-14-XX, Manufacturer Pepperl & Fuchs

Mono-stable                    Type    RC 10/15-14-N0

Bi-stable                        Type    RC 10/15-14-N3

Ex-Marking                    PTB 99 ATEX 2128 X  
II 2G Ex ia IIC T6...T1 Gb

#### 5.3.2 Add-on limit switches Type N7R\*\*A, Manufacturer ifm electronic

Mono-stable                    Type    N7R28A (I7R2010-N - Internal diameter 10mm)

                                      Type    N7R30A (I7R2015-N - Internal diameter 15mm)

Bi-stable                        Type    N7R29A (I7R2010-NL - Internal diameter 10mm)

                                      Type    N7R31A (I7R2015-NL - Internal diameter 15mm)

Ex-Marking                    BVS 08 ATEX E026 / IECEx BVS 09.0016  
II 1G Ex ia IIC T\* Ga  
II 1D Ex ia IIIC T\*\*\*°C Da

\* Refer to certificate for temperature classifications

When installing electrical equipment in hazardous areas please pay attention to the conditions specified in the applicable approval certificate.

### 5.4 Measuring accuracy

Reference conditions

Water 20 °C (air 20 °C; 1.013 bar abs.)

Measurement error

(Liquid/Gas):  $\pm 3\%$ ,  $qG=50\%$  acc. VDE/VDI 3513 page 2

V / N (optional differential pressure regulator):

Measurement error / regulator deviation:  $\pm 3.5\%$  /  $\pm 5\%$  of full-scale within 10-100 % of range

Repeatability

(Liquid/Gas)  $\pm 1.0\%$  full-scale

V / N (optional differential pressure regulator):

Measurement / regulator deviation:  $\pm 1.5\%$  /  $\pm 2.5\%$  of full-scale within 10-100 % of range.

Influence of ambient temperature

none

Influence of fluid temperature

Deviations in fluid temperature from that of the temperature observed during calibration can result in a proportional display fault because of the corresponding change in density.

Temperature-related changes in viscosity will cause a non-linear display fault.

## 6. Conditions of use

The VDI/VDE guidelines must be observed.

The devices can be used for:

- liquid products that are sufficiently free-flowing, are free of solids, do not bond or do not tend to settle.
- gases with linear flow behaviour and an adequate inlet pressure.

V/N (optional differential pressure regulator)

The minimum differential inlet and outlet pressures must amount to 350 mbar.

Please refer to the instructions for potentially hazardous products in Section 3.2.2.

### 6.1 Safe operation

#### 6.1.1 General conditions for safe operation

- a) If the conditions described in this document are not adhered to, or if there is any inappropriate interference with the equipment, all the manufacturer's warranties shall be considered void.
- b) Conditions described in this manual, as well as the permitted operating conditions which have been defined for the sensor and which are stated on the rating plates must be adhered to.
- c) Appropriate measures shall be met to prevent any unintentional or inadmissible damage to the device.
- d) The operator shall ensure that the equipment is only installed in areas which comply with the approved types of protection and environments.
- e) All connected electrical equipment must be suitable for its intended use.
- f) The operator shall ensure protection against lightning according to local regulations.
- g) The flowmeter is maintenance-free.

#### 6.1.2 Requirements for installation in all environments

- a) The installation of the intrinsically safe circuits requires a control drawing (system description), to be issued by the operator/erector.
- b) The equipment is only to be installed and connected in a de-energized state.
- c) It is to be insured that intrinsically safe circuits are not laid together with non-intrinsically safe circuits.
- d) Seized screws or adhering joints (e.g. by frost or corrosion) are not to be opened with force in the presence of a potentially explosive atmosphere.
- e) Where substances of explosion group "IIC" or "A" are present and the presence of an Ex-atmosphere is considered possible, only non-sparking tools shall be used.

#### 6.1.3 Requirements for installation dust environments

- a) In certain circumstances, the non-metallic parts of the sensor may generate an ignition-capable level of electrostatic charge. Therefore, the user/installer shall implement precautions to prevent the build-up of electrostatic charge, e.g. locate the equipment where a charge-generating mechanism (such as wind-blown dust) is unlikely to be present.
- b) Clean the flowmeter regularly with a damp cloth.
- c) Dust deposits with a thickness of more than **5 mm** are to be avoided.
- d) The flowmeter is to be electrostatically earthed. Electrostatic charging must be avoided.

#### 6.1.4 Mounting and commissioning

When installing and commissioning the flowmeter, the following points must be observed:

- a) The variable-area flow meter must be installed perpendicularly (bottom-up direction of flow).
- b) Take special care to install glass-tube devices free from strain.
- c) The size of the product line to be connected must be identical to the size of the device connection.
- d) All instruments are shipped with the valve installed at the inlet. By flipping the glass tube in its fitting and then the instrument, the valve also can be positioned at the outlet.
- e) V / N: for the measurement of gas, the "valve at the top" version for a constant inlet pressure should be used and the "valve at the bottom" version for a constant counter pressure. For liquids, the position of the valve has no impact on the function of the meter.
- f) Open the upstream and downstream shut-off valves of the flowmeter slowly.
- g) When measuring liquids, vent the pipes carefully.
- h) When measuring gases, increase pressure slowly.
- i) Avoid float impact (e.g. caused by solenoid valves), impacts may damage the measuring section or/and float.

### 6.2 Ambient conditions

#### 6.2.1 Ambient temperature ranges

without limit switch	-20 °C to +100 °C
with limit switch	-20 °C to +70 °C

Risk of breakage due to frost

#### 6.2.2 Storage temperature

-20 °C to +100 °C

#### 6.2.3 Climatic category

Weather-protected and/or unheated locations.

Class C according to IEC 654 Part 1

#### 6.2.4 Degree of protection

IP65 (EN60529)

#### 6.2.5 Shock resistance/vibration resistance

The meter should be protected against shocks and vibrations, which could cause damage to the glass tube.

#### 6.2.6 Electromagnetic compatibility

Built in limit switch:

According to:	NAMUR recommendation NE 21
Product standard:	EN 60947-5-2

### 6.3 Fluid conditions

#### 6.3.1 Fluid temperature ranges

without limit switch	-20 °C to +100 °C
with limit switch	-20 °C to +70 °C

Risk of breakage due to frost

Risk of breakage due to frost

6.3.2 Fluid pressure limit  
16 bar (at 20 °C)



Caution!

All pressure values refer to non-hazardous liquids and for devices installed free from strain.

For V / N, the maximum unilateral pressure resistance of the diaphragm is 7 bar.

---

6.3.3 Inlet and outlet sections

Inlet and outlet sections are not required for a linear flow profile of the fluid.

6.3.4 Physical state

Liquid or gaseous

6.3.5 Pressure for gas measurement

The measured values only apply to the calibrated fluid data stated on the scale. Any change or deviation in pressure will cause an indication fault.

6.3.6 Pressure loss

Dependant on the measuring range. (see measuring range table in Section 5.2)

## 7. Construction details

### 7.1 Design/dimensions K09

The meter consists of a conical measuring tube made of borosilicate glass, with a vertical movable float made of stainless steel or glass. The measuring tube is mounted vertically in the device fitting, which possesses two process connections, arranged perpendicularly to the measuring tube, on its rear.

The standard version of the device is equipped with an adjusting valve at the outlet

K09 (dimensions in mm)

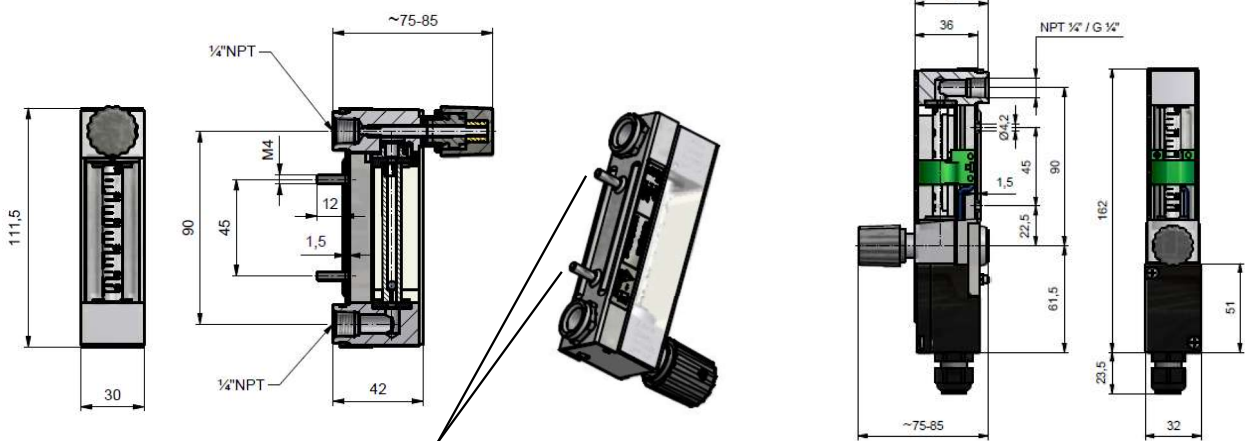

The M4 threaded pins are only an integral part of the delivery if the option „Wall Mounting“ has been selected.

K09 with terminal box

### 7.2 Design / Dimensions / Commissioning V / N (option diff. pressure regulator)

Differential pressure regulators are used to achieve constant flow values at varying inlet and outlet pressures.



Caution!

Differential pressure regulators are not pressure reduction valves

The measuring device consists of a variable area flowmeter with control valve and mounted differential pressure regulator.

The desired flow rate can be adjusted via the integrated adjusting valve.

The maximum one sided pressure resistance of the regulator membrane is 7 bar. If the operating pressure exceeds 7 bar, the control valve must not be fully closed as this leads to overstressing of the membrane.

**IMPORTANT COMMISSIONING NOTES**

- The installation of a valve before the inlet and outlet of the instrument shall be avoided
- Initial operation / start-up of the process only with opened control valve
- When operating with gas the inlet pressure shall be increased slowly to avoid strong pressure peaks.
- To prevent excessive acceleration of the float, operation of the instrument by means of solenoid valves should be avoided.
- For the operation of the regulator minimum inlet pressures are required.
  - Regulator with constant outlet pressure: 350 mbar
  - Regulator with constant inlet pressure: 350 mbar

**7.2.1 Dimension drawing K09-N as regulator c/w constant outlet pressure**

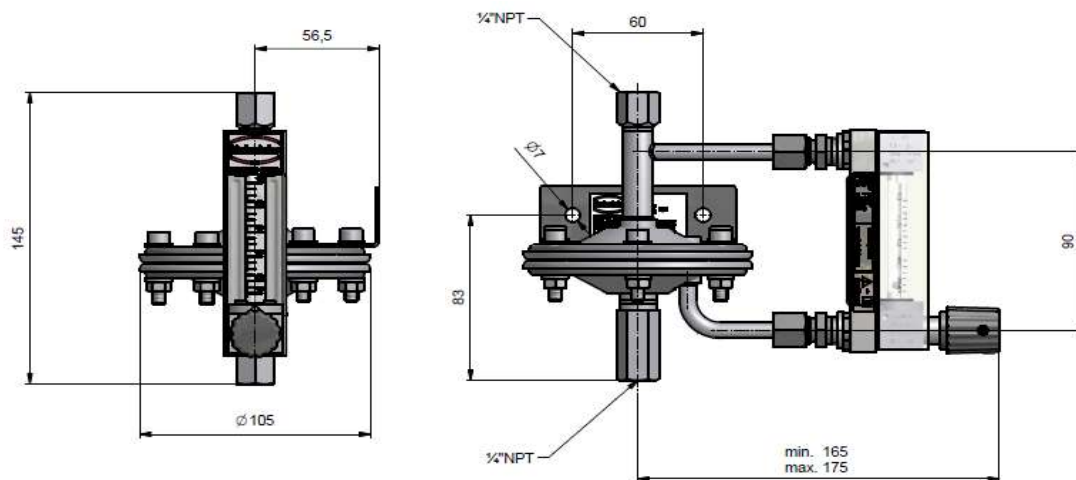

**7.2.2 Dimension drawing K09-V as regulator c/w constant inlet pressure**

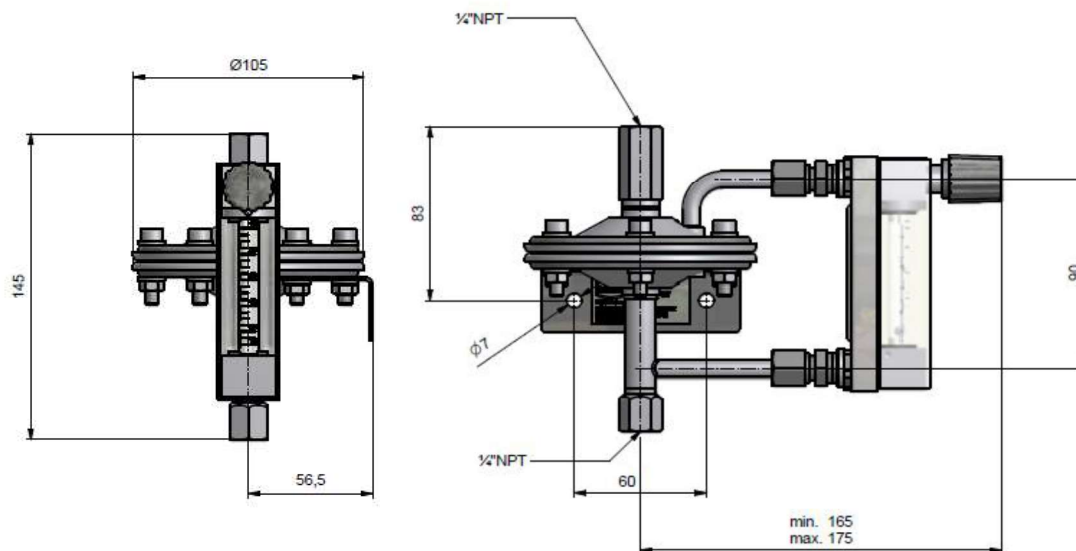

**7.3 Weight:**

K09: 0,4kg,  
K09-....V/N: 0.8 kg

**7.4 Materials:**

Fitting, connections, setting valve: 1.4404 (SS316L)  
Float: 1.4401 (SS304) / glass

Seals:

Measuring tube: Viton, FFKM (option)  
Valve: PTFE,  
Hose-fittings: PVC

V/N (option differential pressure regulator):

Regulator/control pipes: 1.4301(SS304)  
Diaphragm: Viton or PTFE

**7.5 Process connection:**

Standard: NPT $\frac{1}{4}$ " (F)  
Special connections: Ermeto, Swagelok, G  $\frac{1}{4}$ ", Hose connector 8 mm via adaptor.



Note

Other connections are available as special versions

## 8. Electrical connection for limit switch (option)

with cable length of 2 m

The limit switch (ring form) can be adjusted up and down the measuring tube. It is fixed via two screws (1) at the back wall of the instrument.

Adjusting of the contact:

- release the fixing screws (1)
- move contact (2) up or down
- secure the fixing screws (1)

ATTENTION: limited switching range

Measuring ranges 87, 78 and all ranges with glass float cannot be equipped with contact. For the measuring tubes N° 77 and 86 the contact cannot be moved to the max. flow range.

Wiring diagram for limit switch

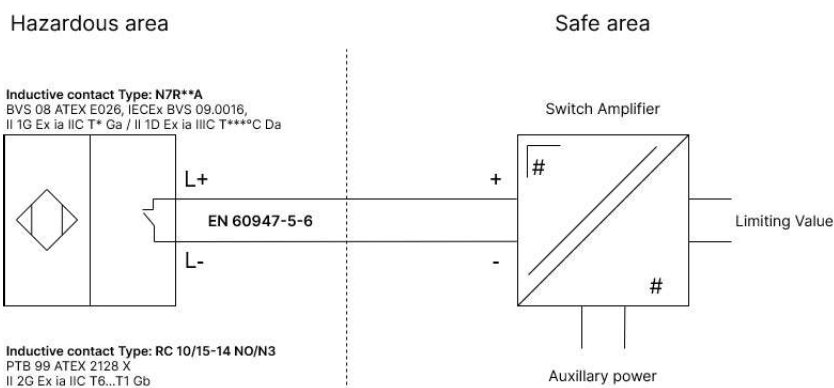
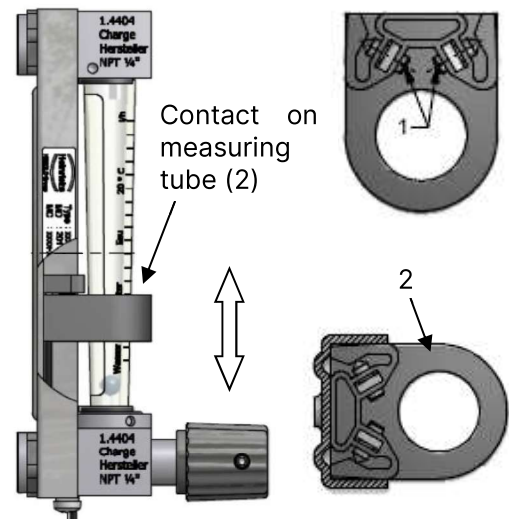

## 9. Indicator unit

Direct indication of the position of the float in the measuring tube via magnetic transmission

## 10. Use in hazardous areas

### 10.1 General Information on Ex-Protection

2014/34/EU (ATEX) / UKCA 2016 Regulations (UKEX)	<b>Example designation</b>			II	2G	Ex	h	IIC	T6	Gb
	<b>Equipment groups</b>									
	I	Equipment group I applies to equipment intended for use in underground parts of mines as well as those parts of surface installations of such mines endangered by firedamp and/or combustible dust.								
	II	Equipment group II applies to equipment intended for use in other places liable to be endangered by explosive atmospheres. This group is subdivided into three categories.								
	<b>Equipment category</b>									
	Gas	Dust	Definition							
	1G (0)	1D (20)	Equipment in this category is intended for use in areas in which explosive atmospheres caused by mixtures of air and gases, vapours or mists or by air/dust mixtures are present continuously, for long periods or frequently.							
	2G (1)	2D (21)	Equipment in this category is intended for use in areas in which explosive atmospheres caused by gases, vapours, mists or air/dust mixtures are likely to occur.							
	3G (2)	3D (22)	Equipment in this category is intended for use in areas in which explosive atmospheres caused by gases, vapours, mists, or air/dust mixtures are unlikely to occur or, if they do occur, are likely to do so only infrequently and for a short period only.							
	(The numbers in round brackets correspond to the IEC Zones.)									
Acc. EN 60079-0 ff	<b>Ex = Explosion-proof equipment</b>									
	<b>Examples of electrical types of protection</b>									
		General requirements	EN DIN 60079-0							
	„d“	Flameproof enclosure (db, dc)	EN DIN 60079-1							
	„e“	Increased safety (eb, ec)	EN DIN 60079-7							
	„i“	Intrinsic safety (ia, ib, ic)	EN DIN 60079-11							
	„t“	Equipment dust ignition protection by enclosure "t" (ta, tb, tc)	EN DIN 60079-31							
	<b>Non-electrical types of protection</b>									
	„h“	Basic Method and requirements	DIN EN ISO 80079-36							
		Schutz durch konstruktive Sicherheit	DIN EN ISO 80079-37							
<b>Explosion groups</b>										
Gases and vapours										
IIA	Acetone, benzene, fuel oil, ethanoic acid									
IIB	City gas, ethylene, isoprene									
IIC	Acetylene, hydrogen, carbon bisulphide									
Dust Atmospheres										
IIIA	Fibers and flyings									
IIIB	Non-conductive dusts									
IIIC	Metal dusts									
<b>Temperature classes</b>										
	Maximum surface temperature	Temperature class								
	450 °C	842 °F	T1							
	300 °C	572 °F	T2							
	200 °C	392 °F	T3							
	135 °C	275 °F	T4							
	100 °C	212 °F	T5							
	85 °C	185 °F	T6							
<b>Equipment protection level, EPL</b>										
Gases: Ga, Gb oder Gc		Dust: Da, Db or Dc								

Explosion protection designations [square brackets] refer to "Related electrical equipment or circuits."



Note!

Only devices with Ex-markings may be operated within areas with potentially explosive atmospheres



Ambient Temperature	Process Temperature	Marking	Zone	Description
-20 °C ...+70 °C	-25 °C ...+70 °C	II 2G Ex h IIC T6 Gb II 2D Ex h IIIC T85°C Db	1	With built-in switch, observe the type certificate of the contact manufacturer!
-20 °C ...+100 °C	-25 °C ...+100 °C	II 2G Ex h IIC T6...T5 Gb II 2D Ex h IIIC T85°C...T100°C Db	1	As a purely mechanical device

## 10.2 Atmospheric Conditions

According to EN 1127-1, a "potentially explosive atmosphere" is defined as a mixture of air and combustible gases, vapour, mist or dust under atmospheric conditions. These conditions are defined in DIN EN ISO 80079-36, para. 1, with values  $T_{atm} = -20\text{ °C}$  to  $+60\text{ °C}$  and  $P_{atm} = 0,8$  to  $1,1$  bar. Outside of this range, safety parameters for most ignition sources are not available.

The operating conditions inside the measuring tubes of variable-area flow meters generally lie outside the atmospheric conditions of 0,8 to 1,1 bar. Therefore, due to the lack of safety parameters, the explosion protection does not apply to the process conditions inside of the measuring tube, irrespective of the zone classification.

Operation with combustible products is therefore only permissible if a potentially explosive air mixture is not formed inside the flow meter. Where this condition is not met, the operator is required to assess the ignition hazard in each individual case giving due consideration to existing parameters (e.g. pressure, temperature, process product, materials)

## 10.3 Electrostatic charge of non-conductive parts

In hazardous areas the risk of electrostatic charge in dangerous quantities must be considered during cleaning of the measuring tubes synthetic cover.

Devices where explosive electrostatic charges are to be expected are marked with an adhesive label. Use a damp cloth for cleaning of the synthetic materials.



Warning!

Danger of electrostatic charge!

Do not rub!

### 10.3.1 Grounding

In variable-area flow meters, under operating conditions it is possible for charge separation to occur in the measuring tube due to the transport of non-conductive fluids. For this reason, variable-area flow meters must be permanently grounded by the operator by way of the process connections (flanges) to ensure the discharge of electrostatic build-up.

If grounding cannot be guaranteed via the process connections (e.g. plastic process connections), the flow meter must be connected to the local ground potential via the flanges. This connection only ensures electrostatic grounding of the device and does not meet the requirements for equipotential bonding.

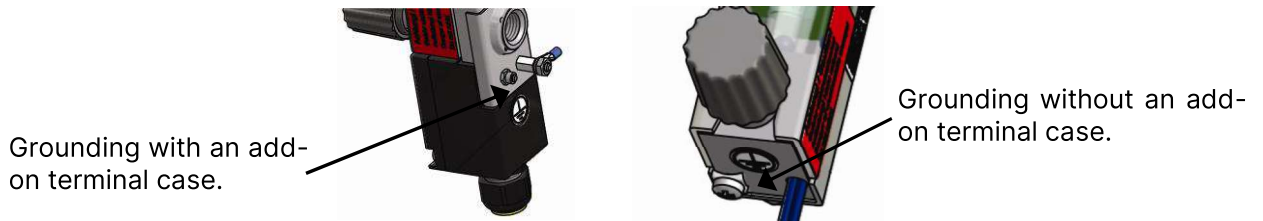



### 10.4 Mechanical strength

The device with its glass measuring tube is to be mounted in such a way that it is protected from mechanical damages.

### 10.5 Without electrical equipment

The basic version of the flow meter is a non-electrical device without its own ignition source and meets DIN EN ISO 80079-36 requirements. It can be used in hazardous areas that require Category 2 equipment.

Marking	
	II 2G Ex h IIC T6..T5 Gb II 2D Ex h IIIC T85°C/100°C Db Reg. No.: BVS 10 ATEX H-B 034 Tech. File: EE0097-3001-X
	II 2G Ex h IIC T6..T5 Gb II 2D Ex h IIIC T85°C/100°C Db Reg. No.: BAS 22 UKEX 0160 TDR Tech. File: EE0097-3001-X



Since the device does not possess its own power sources that could lead to a temperature increase, the fluid temperature is decisive for the maximum surface temperature.

### 10.6 With limit switch

With the installation of a limit switch, the device becomes an electrical assembly and receives an additional marking in accordance with DIN EN 60079-0.

The electrical and thermal data and the special conditions of the relevant EU Type Examination Certificate must be observed.

Marking of the limit transducer:

Manufacturer Pepperl & Fuchs Type: RC 10/15-14 NO/N3		PTB 99 ATEX 2128 X II 2G Ex ia IIC T6 Gb
Manufacturer ifm electronic Type: N7R**A		BVS 08 ATEX E026 / IECEx BVS 09.0016, II 1G Ex ia IIC T* Ga II 1D Ex ia IIIC T***°C Da

The influence of the fluid temperature on the built-in limit transducer must be observed.

\* Refer to Type Certificate for temperature classifications

## 11. CE marking

The measuring system meets the statutory requirements of the following EU directives:

- 2014/34/EU (ATEX) Equipment for Use in Potentially Explosive Atmospheres
- 2014/30/EU (EMC) Electromagnetic Compatibility.

With respect to the Pressure Equipment Directive 2014/68/EU, the devices fall within the scope of application of Article 4, Paragraph 3, and therefore requires no CE marking in accordance with this directive.

By attaching the CE logo to the device, Heinrichs Messtechnik confirms compliance with these directives.

### 11.1 Standards and directives

VDE/VDI 3513	Measuring range rated and converted to other products
DIN EN ISO 80079-36	Non-electrical equipment for use in potentially Explosive Atmospheres

For the electrical sensor

EN 60079-0	Explosion protection; General regulations
EN 60079-11	Explosion protection; intrinsic safety
NAMUR NE 21	recommendation: EMC for industrial processes and laboratory
EN 60529	Degrees of protection through housing (IP code)
EN 61010-1	Safety requirements for electrical measure, control & laboratory devices
EN 60947-5-6	Low voltage switchgear and controlgear (NAMUR)

## 12. Available accessories

- 1 inductive limit switch ; mono-stable or bi-stable
- Special connections

## 13. Order information

Please include the following information in your order:

Product data, (specific weight, temperature, pressure, viscosity) material design, connection size, measuring range, desired accessories, required approvals and material certificates.

## 14. Maintenance

If you use the meter in the intended manner no special maintenance is required. However, the variable area flow meter should be checked in the context of the routine maintenance of the facility and the pipelines. Special attention should be paid to dirt, corrosion denudation, mechanical wear as well damage to the glass cone. We recommend checking the meter once a year.

In the recurrent pressure test of the system, the maximum allowed pressure test PT (see rating plate) must not be exceeded.

### 14.1 Cleaning

Should it become necessary due to contamination to clean the float or the measuring cone, please observe the following precautions:

- Before removing a device, make sure that the pipe line is empty (no product residues) depressurized and has cooled down.
- For devices that are used to measure corrosive or hazardous media, appropriate security precautions must be taken regarding any remaining liquid in the measuring unit.
- Avoid electrostatic charging of surfaces when cleaning non-conductive surfaces (e.g. protective hood). Use a damp cloth.
- Having dismantled the device, dirt or impurities on the inside of glass measuring cones should be gently cleaned with a brush and appropriate media.
- When assembling and reinstalling the system new gaskets must always be used.

## 14.2 Replacing the measuring cone

Images depicting the disassembly and assembly of the device can be found on page 25 in section 14.2.3

### 14.2.1 Removal:

- Close valve in front and behind the unit
- Close needle valve of the device
- Shift protective cover upwards and remove to the front.
- By turning the adjusting ring at the unit base counter clockwise, the measuring glass can be loosened and removed to the front.

### 14.2.2 Installation:

The assembly is performed in the reverse order to the disassembly

- The measuring glass is fixed in place by first clamping the adjusting ring on the unit base hand tight.
- With a 3 mm pin the clamping ring is fixed by 4x, max. 5x for each 120° turns clockwise.
- The torque should be max 2,8 to 3 Nm.
- Caution! To avoid breaking the glass measuring tube it is essential to ensure it is installed centric between the seals.
- Before re-commissioning the tightness of the measuring device is to be checked with suitable means.

### 14.2.3 Depiction of the dis- and reassembly

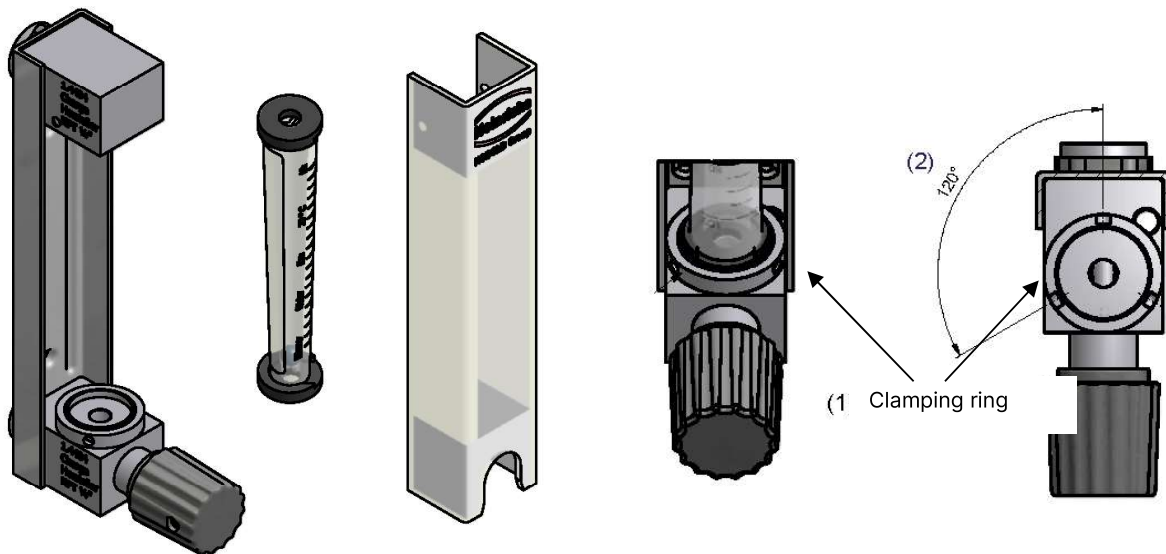

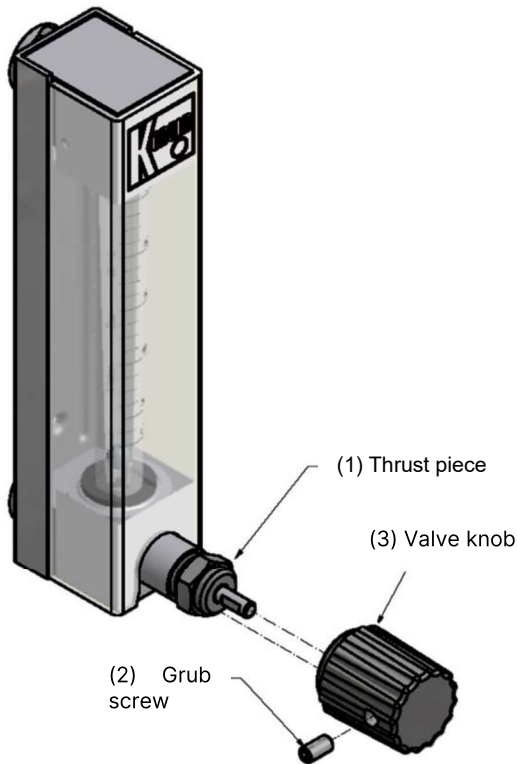

**Caution!**

The shaft packing of the valve must be readjusted during the life cycle. This requires tightening of the thrust piece (1)

Loosen grub screw (2) M4x8 with hexagon 2mm and remove valve knob (3).

Tighten thrust piece (1) SW14 with a torque of 3,8 Nm - 4,0 Nm

**Caution!**

Valves that have not been operated for a long time may require a higher operating torque.



## 15. Returning devices for repair and service



**Note!**

In accordance with the applicable waste disposal legislation, the owner/client is responsible for the disposal of special waste and hazardous materials. Consequently, all devices sent to Heinrichs Messtechnik for repair must be free of any hazardous materials. This also applies to possible cavities and fissures in the devices.

If repair is necessary, the above-mentioned requirement is to be confirmed in writing. Please use the form "Decontamination certificate for device cleaning" in section 16.

If hazardous materials remain in or on the device after it has been returned, Heinrichs Messtechnik is authorized to remove them at the client's expense without further inquiry.

### 16. Decontamination certificate for device cleaning

Referenz: \_\_\_\_\_

Company: \_\_\_\_\_ Town/City: \_\_\_\_\_  
 Name: \_\_\_\_\_ Department: \_\_\_\_\_  
 Tel. N°.: \_\_\_\_\_

The enclosed device

Model: \_\_\_\_\_  
 SN: \_\_\_\_\_

Was operated using the medium \_\_\_\_\_

Since this medium is\* :

- |                                      |                                    |   |
|--------------------------------------|------------------------------------|---|
| <input type="checkbox"/> poisonous   | <input type="checkbox"/> explosive | <input type="checkbox"/> health-hazardous |
| <input type="checkbox"/> oxidising   | <input type="checkbox"/> corrosive | <input type="checkbox"/> bio-hazardous    |
| <input type="checkbox"/> radioaktive | <input type="checkbox"/> other     | <input type="checkbox"/> harmless         |

we have performed the following steps;

- Checked all cavities in the device to ensure that they are free of fluid residues \*
- Washed and neutralized all cavities in the device \*
- Cleaned all seals/gaskets and medium contacted components \*
- Cleaned the housings and all surfaces \*

\* tick applicable items.

We hereby warrant that no health or environmental hazard will arise from any fluid residues on or in the enclosed device.

Heinrichs Messtechnik GmbH explicitly expresses that external cleaning of the devices will be arranged if the decontamination certificate is not received with the goods. All related costs shall be borne in full by the customer

Date: .....

Signature: .....

Company Stamp

## 17. Model Code

Model number	Description	Notes
K09	Installation length: 90mm	
-	<b>Process connection</b>	
N	Female thread - ¼" NPT	
G	Female thread - G ¼" (not with diff. pressure regulator)	
X	Special, customer specified	
-	<b>Process connection - Accessories</b>	
0	without	
1	¼" NPT - Hose connection, PVC, Ø8mm, elbow	
2	¼" NPT - Hose connection, PVC, Ø8mm, straight	
-	<b>Valve position</b>	
0	without	
1	outlet (Standard)	
2	inlet	
	<b>Measuring range</b>	
88	Air 2.0...20 NI/h	1), 3)
89	Air 4.0...40 NI/h	1), 3)
70	Air 5.0...50 NI/h	1)
71	Air 10...100 NI/h	1)
90	Air 12...120 NI/h	1), 3)
72	Air 25...250 NI/h	1)
73	Air 30...350 NI/h	1)
74	Air 50...450 NI/h	1)
75	Air 60...800 NI/h	1)
76	Air 120...1200 NI/h 120...1100 NI/h	1), 4)
77	Air 200...2000 NI/h 200...1500 NI/h	1), 4)
78	Air 300...3000 NI/h	1)
91	Water 0.02...0.25 l/h	2), 3)
92	Water 0.08...0.7 l/h	2), 3)
79	Water 0.1...1.0 l/h	2)
80	Water 0.25...2.5 l/h	2)
81	Water 0.6...6.5 l/h	2)
82	Water 1.0...10 l/h	2)
83	Water 1.6...16 l/h	2)
84	Water 2.5...25 l/h	2)
85	Water 4.0...40 l/h 4...35 l/h	2), 4)
86	Water 6.0...63 l/h 6...40 l/h	2), 4)
87	Water 10...100 l/h	2)
XX	Special range Valve Ø, Float Ø and Material can variate	
-	<b>Scale</b>	
0	Standard - range	
1	% Scale (Water/Air) (add-on special range)	
2	Product scale (add-on special range)	
3	Product scale % (add-on special range)	
X	Special, customer specified	
-	<b>Sealing glass tube</b>	
V	Viton (Standard)	
P	FFKM	
M	PTFE	
X	Special, customer specified	
-	<b>See accessories for further specification ...</b>	

- 1) Air (20°C, 1,013 bar abs).
- 2) Water (20°C, 1000kg/m<sup>3</sup>, 1mPas)
- 3) Switch not applicable
- 4) Limited adjustment range of the limit switch / only 1x limit switch can be adjusted as min. contact.

Accessories

Model number	Description	Notes
-	<b>Wall / Panel mount</b>	
0	without	
S	Panel mount	
W	Wall mount	
	<b>Contacts</b>	
0	without	
M	Inductive ring sensor. Mono-stable (IFM N7RXXX I7R201X-N/2M/1G/1D)	
B	Inductive ring sensor. Bi-stable (IFM N7RXXX I7R201X-NL/2M/1G/1D)	
	<b>Number of contacts</b>	
0	without	
1	1x	
	<b>Terminal box</b>	
0	without	
A	with not for panel mounting	
	<b>Flow - differential pressure regulator</b>	<b>Valve position</b> <b>Material membrane</b>
00	without	
VV	inlet pressure constant / outlet pressure variable (HV)	outlet Viton 5) 7)
NV	outlet pressure constant / inlet pressure variable (HN)	inlet Viton 5) 7)
VB	inlet pressure constant / outlet pressure variable (HV)	outlet Perbunan 5) 7)
NB	outlet pressure constant / inlet pressure variable (HN)	inlet Perbunan 5) 7)
VP	inlet pressure constant / outlet pressure variable (HV)	outlet PTFE 5) 7)
NP	outlet pressure constant / inlet pressure variable (HN)	inlet PTFE 5) 7)
	<b>Approval</b>	
0	without	
1	ATEX II 2G Zone 1	
	<b>Design</b>	
-	Heinrichs	
H	Heinrichs	
K	Kobold	
N	neutral	
X	Special, customer specified	
	<b>Marking</b>	
0	without	
1	St. St. plate 40x20mm	
	<b>Certificates</b>	
0	without	
1	Certificate of compliance with the order 2.1	
2	Test report 2.2	
B	Inspection certificate 3.1 with material certificate (DIN EN 10204:2004)	6)
	<b>Other testing</b>	
0	without	
X	Special, customer specified	
	<b>Calibration report</b>	
0	without	
1	Confirmation of the accuracy class	
2	5-Point calibration report	
4	Special, customer specified	
	<b>Cleaning</b>	
0	without	
1	Cleaning "oil and grease free"	
2	Cleaning "oil and grease free" incl. Marking	

- 5) Not for panel mount. NPT connection only
- 6) Not in combination with differential pressure regulator
- 7) max. differential pressure 7 bar

Version: 2024.01

Heinrichs Messtechnik GmbH Robert-Perthel-Strasse D 50739 Cologne Telephone: +49 (221) 4 97 08 - 0 Telefax: +49 (221) 4 97 08 - 178 Internet: <a href="http://www.heinrichs.eu">http://www.heinrichs.eu</a> e-mail: <a href="mailto:info@heinrichs.eu">info@heinrichs.eu</a>	Printed in the Federal Republic of Germany 9	File: DRAFT_VIL_K09_BA_23. 01_EN
--	---	--