

# Variable Area Flow Meter

For horizontal and vertical installation

## BGF

### Technical Information

- Extreme robustness due to guide stars instead of rod guides
- Suitable for all flow directions
- Flow measurement of liquids and gases
- Outstandingly clear reading due to 90° arranged scale
- Electrical transmitter with HART® or Fieldbus Foundation®
- Suitability for installation in safety-related measuring systems according to SIL

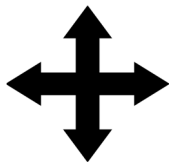
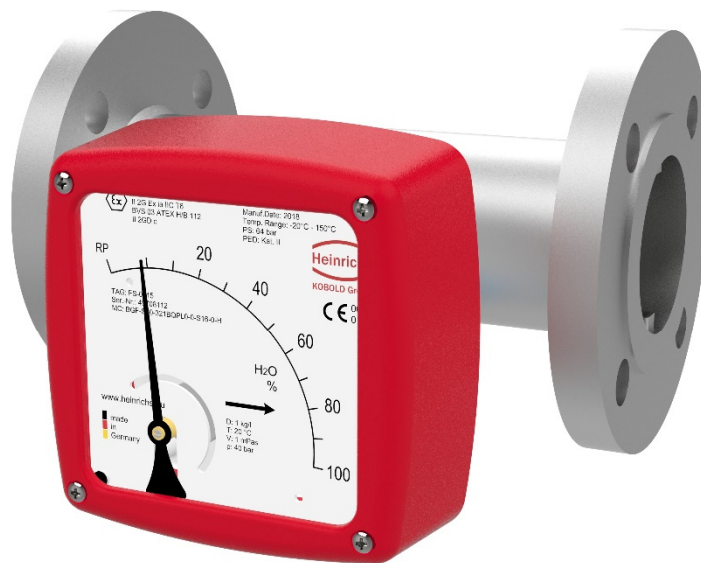

For all flow directions



## Function

The measuring element consists of a sharp-edged measuring ring (2) and a conical measuring body (3) with a compression spring (1).

If a medium flow through the measuring ring (2) with sufficient flow velocity, the measuring body position shifts until a state of equilibrium is reached between the applied flow force and the measuring body plus spring force.

The position of the measuring body (3) in the measuring ring (2) serves as a measure of the flow rate and is converted into a rotary movement by the permanent magnet encapsulated in the measuring body (3) via a magnetic sequence system (4). This rotary movement is transmitted to the scale (5) and, if required, to the additional electrical equipment (e.g. electrical transmitter, contacts) in the display housing (6).

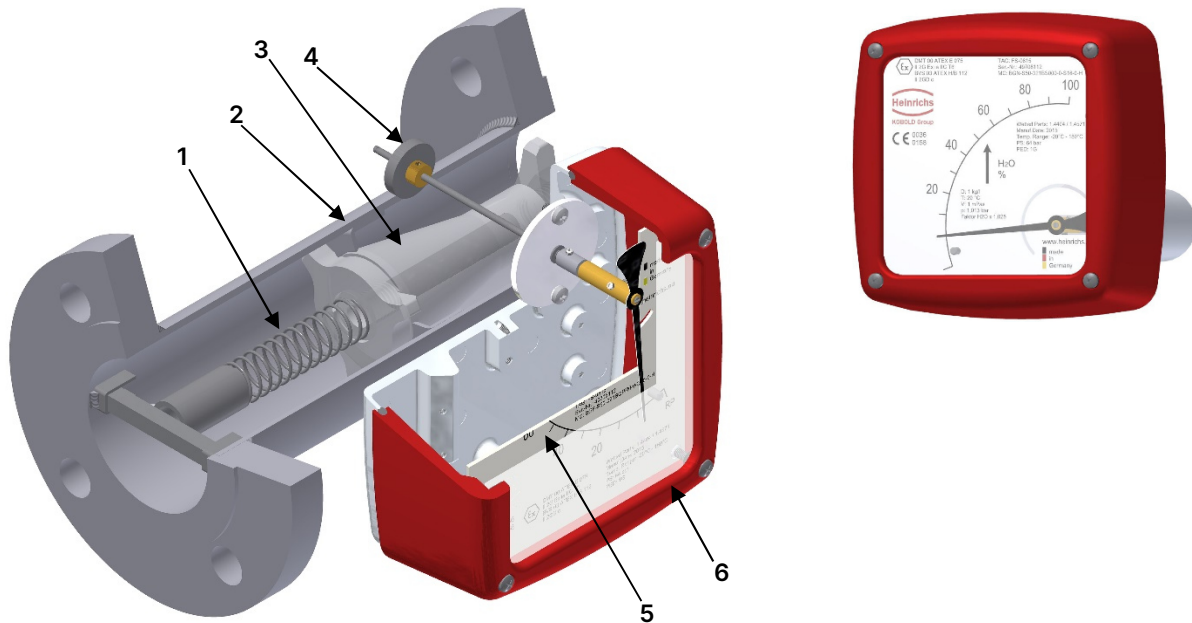

## Application

The BGF instrument is suitable for flow measurement of liquid or gaseous fluids in a pipe.

Indicated will be the actual flow in volume or mass per time.

### Applications:

- Flow measurement
- Monitoring
- Adjusting
- Control of liquid and gaseous products

The meter design makes it ideal for processes under difficult and rough operating conditions.

The devices are available with additional electrical equipment for process monitoring and control.

### Features:

- Permanent magnetic signal transmission
- Applicable for high-pressure applications and high-temperature processes
- Excellent heat tracing technology (option)
- Double eddy current damping (option)

## Design / Variation

### Aluminum indicator

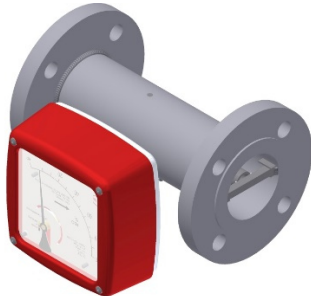

Optimized aluminium display

Large and well-arranged scale 90° angle for best reading.

Rounded edges and rims ensure a smooth draining of liquids after wet contact. A special anodization and paint finish make the indicator housing also suitable for outdoor use.

Process connections: flange, thread, clamp, weld ends

### Stainless steel indicator



Stainless steel indicator

Large and well-arranged scale with 90° angle for optimal reading. IP65, IP66, IP67 protection for extreme applications.

The round design ensures a smooth draining of liquids after wet contact. Salty and rough environments such as off-shore applications do not show any problems.

### High temperature with displaced indicator

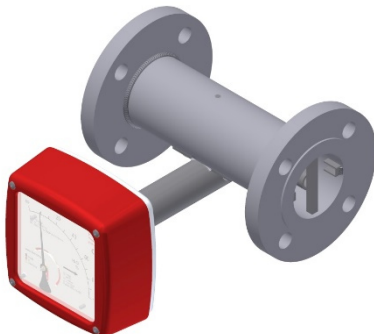

Forward advanced indicator for process temperatures up to 200°C

For very high or very low process temperatures the indicator will be displaced 100 mm from the measuring pipe.

The use of limit switches or transmitters are without limitations.

### Linings / special materials



PTFE lining for highest resistance

This lining allows the use in special environments or for highly corrosive processes such as acids and lyes.

Temperature max. 125°C

Max. pressure resistance 16 bar

### High-pressure version

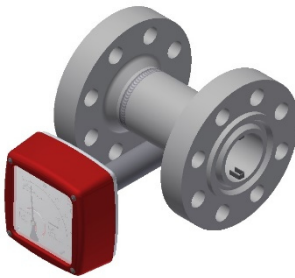

Due to the unique design of the measuring fitting with cylindrical measuring tube and conical float, the devices can be manufactured with thick-walled measuring tubes without any problems. This allows the use in high-pressure applications for which there are otherwise hardly usable measuring devices.

e.g. high-pressure cooling lubrication systems

### Instrument with heating jacket

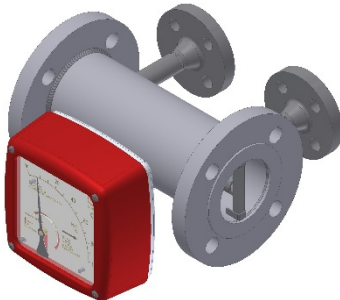

The cylindrical measuring pipe allows a double-walled construction and the connection of a medium heater, e.g. for steam, hot water or thermal oil, without difficulty.

This enables the use for extremely difficult media or operating conditions.

The connections for the medium heating are made according to customer requirements.

### Assembly / Special solutions

We develop solutions for individual measuring tasks in close cooperation with our customers.

We develop and manufacture application-related assemblies according to customer requirements - e.g. with valves, flow regulators, including piping, etc..

## Technical Data

### Fitting

#### Materials:

- 1.4404 (316 L) / 1.4571 (316 Ti), spring stainless steel 1.4571
- PTFE, spring Hastelloy HC 4 (2.4610)  
Special materials on request

#### Process connection:

- Flange according to
  - DIN EN 1092-1
  - ASME B16.5-2003
  - JIS, NPT, Tube fitting

Special materials on request

#### Nominal pressure:

- PN 40, ASME C1150 / 300 (Standard) (BGF-S)
- PN 16, ASME C1150 (Standard) (BGF-P)

Higher pressures on request.

#### Process temperature:

- -40 C ... + 200°C (BGF-S)
- -40 C ... + 125°C (BGF-P)

#### Environmental temperature:

- -40°C ... + 80°C without electric accessories
- -25°C ... +70°C / +80°C with limit switches
- -40°C ... + 70°C with ES transmitter

#### Measurement deviation:

- BGF-S/P
  - Water : ± 2% of the measured value
  - Gas : ± 2,2% of the measured value
  - qG 50% acc.to VDI/VDE 3513-2
- ± 0,2% additional error with transmitter ES

#### Repeatability:

- ± 0,5 %

### Display Unit

#### Protection class:

- Aluminum IP65
- Stainless steel IP65, IP66, IP67

#### Electrical outputs

#### Switching outputs:

- max. 2 inductive switch contacts (SJ 3,5 N)  
⊕ Refer to type approval for elec. parameters
- max. 2 inductive switching contacts (SJ 3,5 SN)  
(safety design)  
⊕ Refer to type approval for elec. parameters
- max. 2 micro changeover switches  
(Reed switch  $U_{max}$ :175V<sub>DC</sub>,  $I_{max}$ :0,25A,  $P_{max}$ :5W)

#### Transmitter ES:

- ES with HART®- Protokoll
- ES with HART®- Protokoll and 2 NAMUR-contacts
- ES with HART®- Protokoll and 1 NAMUR-contact and 1 pulse output
- ES with HART®-Protocol and counter module  
(only for flow direction from bottom to top)
- ES with Foundation FIELDBUS®

#### Power supply transmitter ES:

- 14 ... 30 V<sub>DC</sub>

#### Outputs Transmitter ES:

passive, galvanic isolated

- Analogue: 4...20 mA with HART®  
⊕  $U_i=30$  V,  $I_i=150$  mA,  $P_i=1$  W
- Binary 1 and 2: 2x Contacts  
⊕  $U_i=30$  V,  $I_i=20$  mA,  $P_i=100$  mW
- FF:  
⊕  $U_i = 17.5$  V<sub>DC</sub> (FISCO), or  
 $U_i=32$  V<sub>DC</sub>,  $I_i=280$  mA,  $P_i=2$  W
- Counter Module (non-Ex):
  - Power Supply:  
 $U_{max}=30$  V<sub>DC</sub>,  $I_{max}≤10$  mA
  - Binary input: Reset counter reading  
 $U_{max}=30$  V<sub>DC</sub>
  - NPN Outputs  
 $U_{max}=30$  V<sub>DC</sub>,  $I_{max}=20$  mA

#### Protection class transmitter ES:

- IP20 (EN60529)

#### ATEX and IECEx:

Refer to Certificates and Approvals

For electrical parameters refer to certificates

## Measuring ranges

DIN EN1092-1 <sup>4)</sup>	ASME B16.5-2003 <sup>4)</sup>	Fitting S ... Stainless steel P ... PTFE	Measuring range	Measuring range for water (1000 kg/m <sup>3</sup> ; 1 mPas)	Measuring range for air (1,013 bar abs., 20°C) <sup>3)</sup>	Pressure loss
				[l/h]	[m <sup>3</sup> /h]	[mbar]
15	1/2"	(S/P)15 <sup>1)</sup>	H	10...100	0,3...3	110
20	3/4"	(S/P)15 <sup>1)</sup>	I	16...160	0,5...4,6	110
25	1"	(S/P)15 <sup>1)</sup>	J	25...250	0,7...7,0	110
32	1 1/4"	(S/P)15 <sup>1)</sup>	K	40...400	1,0...11	110
		(S/P)15 <sup>1)</sup>	L	60...600	1,7...17	120
15	3/4"	(S/P)25 <sup>1)</sup>	M	100...1.000	3...30	90
20	1"	(S/P)25 <sup>1)</sup>	N	160...1.600	4...46	105
25	1 1/4"	(S/P)25 <sup>1)</sup>	P	250...2.500	7...70	130
32	1 1/2"	(S/P)25 <sup>1)</sup>	Q	400...4.000	11...110	240
		(S)40 <sup>1)</sup>	P	250...2.500	7...70	75
40	1 1/2"	(S)40 <sup>1)</sup>	Q	400...4.000	11...110	110
		(S)40 <sup>1)</sup>	R	600...6.000	17...170	130
		(S)40 <sup>1)</sup>	S	1000...10.000	29...290	120
		(S/P)50 <sup>2)</sup>	Q	400...4.000	11...110	100
50	2"	(S/P)50 <sup>2)</sup>	R	600...6.000	17...170	110
65	2 1/2"	(S/P)50 <sup>2)</sup>	S	1.000...10.000	29...290	120
		(S/P)50 <sup>2)</sup>	T	1.600...16.000	46...460	130
		(S/P)50 <sup>2)</sup>	U	2.500...25.000	70...700	200
		(S/P)80 <sup>2)</sup>	T	1.600...16.000	46...460	110
80	3"	(S/P)80 <sup>2)</sup>	U	2.500...25.000	70...700	130
	3 1/2"	(S/P)80 <sup>2)</sup>	V	4.000...40.000	110...1.100	200
		(S/P)80 <sup>2)</sup>	W	6.000...60.000	170...1.700	200

Reference conditions: according to IEC 770: Water at 20°C, air at 20°C and 1.013 bar abs

- 1) Magnet carrier made of PTFE or stainless steel.
- 2) Magnet carrier made of PP, PTFE or stainless steel.
- 3) No measurement is possible at atmospheric pressure upstream and downstream of the flowmeter. The values given are for orientation only. For gases, the required upstream pressure should correspond to approx. 2-3 times the pressure loss of the measuring device.
- 4) Restrictions for devices with PTFE lining.

## Materials

Type	Spring	Measuring tube	Measuring tube lining	Flanges	Flange lining	Float
BGF - S <sup>1)</sup>	Stainless steel	Stainless steel	None	Stainless steel	None	PTFE / Stainless steel
BGF - S <sup>2)</sup>	Stainless steel	Stainless steel	None	Stainless steel	None	PP / PTFE/ Stainless steel
BGF - P	Hastelloy	Stainless steel	PTFE	Stainless steel	PTFE	PTFE

- 1) For flange size DN15/25/40 (3/4", 1", 1 1/2" ASME)
- 2) For flange size DN50/80 (2", 3" ASME)

## Certificates and Approvals

---

### Explosion protection:

<b>ATEX (IECEx) Directive</b>	<b>2014/34/EU</b>
BGN (Mechanical Device):	HMT21-4111X (Conformity Statement)
Ex-marking:	II 2G Ex h IIC T1...T6 Gb II 2D Ex h IIIC T85°C/T350°C Db
ES:	DMT 00 ATEX E 075 / IECEx BVS 16.0072
Ex-marking:	II 2G Ex ia IIC T6 Gb
SJ 3,5-N:	PTB 99 ATEX 2219X
SJ 3,5-SN:	PTB 00 ATEX 2049X
Ex-marking:	II 2G Ex ia IIC T6...T1 Gb II 1D Ex ia IIIC T <sub>200</sub> 135°C Da

### KCS (Korea):

ES:	19-KA4BO-0315
Ex-marking:	Ex ia IIC T6

### NEPSI (China):

ES:	GYJ22.1875
Ex-marking:	Ex ia IIC T6 Gb

### PESO (India):

ES:	P568580
Ex-marking:	Ex ia IIC T6 Gb

### Standards applied (EX):

EN 80079-36:	Non-electrical devices: for use in potentially explosive atmospheres.
EN 80079-37:	Non-electrical equipment: protection by Design safety.
EN 60079-0:	General regulations.
EN 60079-11:	Intrinsic safety "i".

### Electromagnetic compatibility:

<b>EMV Directive</b>	<b>2014/30/EU</b>
EN 61326-1:	EMC requirements.
EN 61000-6-2:	Immunity industrial area.
EN 61000-6-3:	Interference emission residential area
EN 55011:	Group 1, Class B, radio interference.
NAMUR 21:	Process and laboratory technology.

### PED Directive: 2014/68/EU

Modules H AD2000 Pamphlets CRN (Canada):	0F16542.5x (x All provinces and territories)
---	--

### SIL

SIL 1:	EXIDA assessment acc. IEC 61508-2:2000 /:2010 (Typ B, Profil 2)
SIL 2: (only with limit-switch):	EXIDA assessment acc. IEC 61508-2:2000 (Typ A, Profil 2)

## Dimensions

### Flange connection – Indicator aluminum

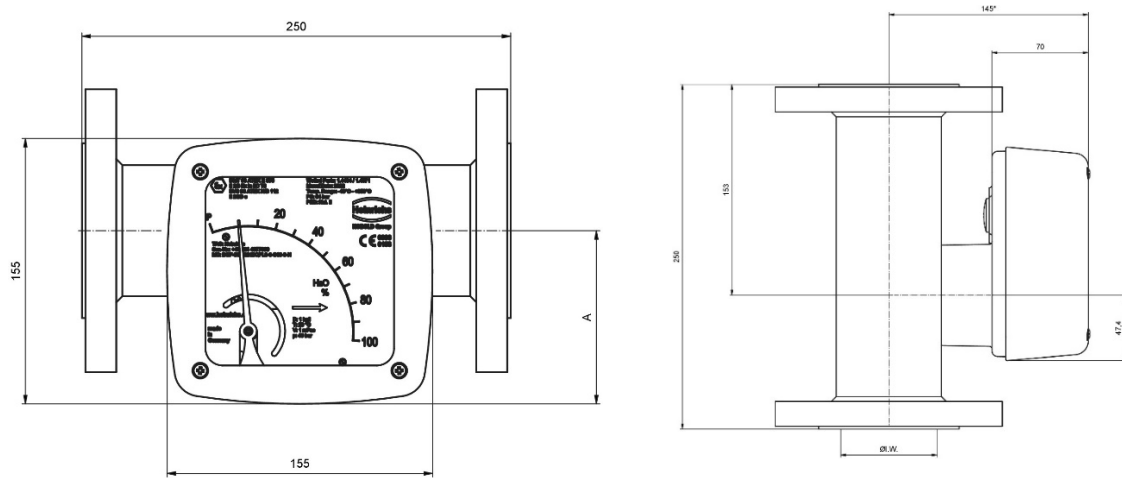

### Flange connection – Indicator stainless steel

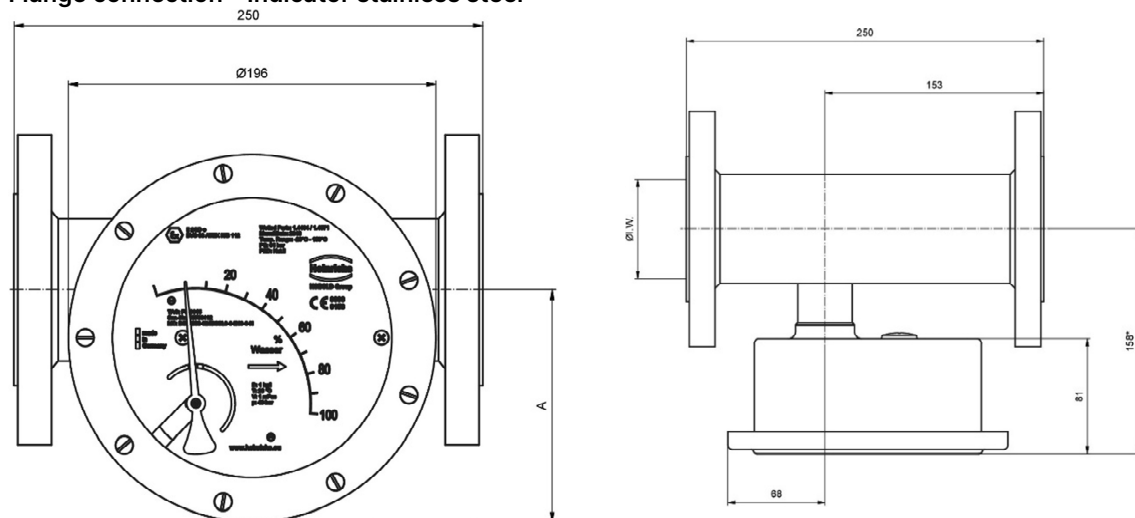

Fitting	DN / ASME	PN / CL	Ø I. W. [mm]	Stainless steel - Display A [mm]	Aluminum - Display A [mm]
S15	15, 1/2"	40 / 150/300	26	99,5	77,0
S25	25, 1"	40 / 150/300	32	102,6	80,1
S40	40, 1 1/2"	40 / 150/300	46	110,4	87,9
S50	50, 2"	40 / 150/300	70	123,4	100,9
S80	80, 3"	40 / 150/300	102	139,7	117,4

Threaded connection – Indicator aluminum

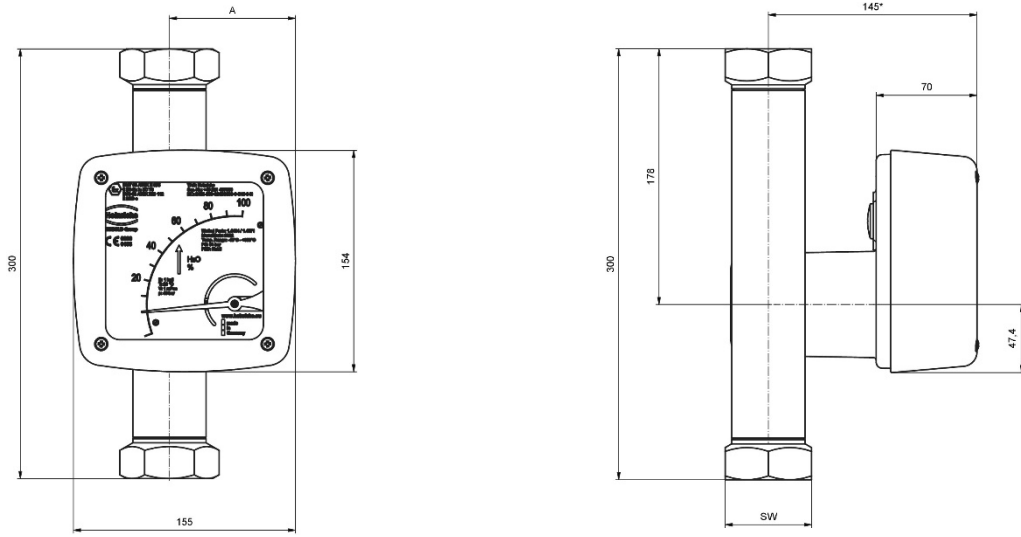

Threaded connection – Indicator stainless steel

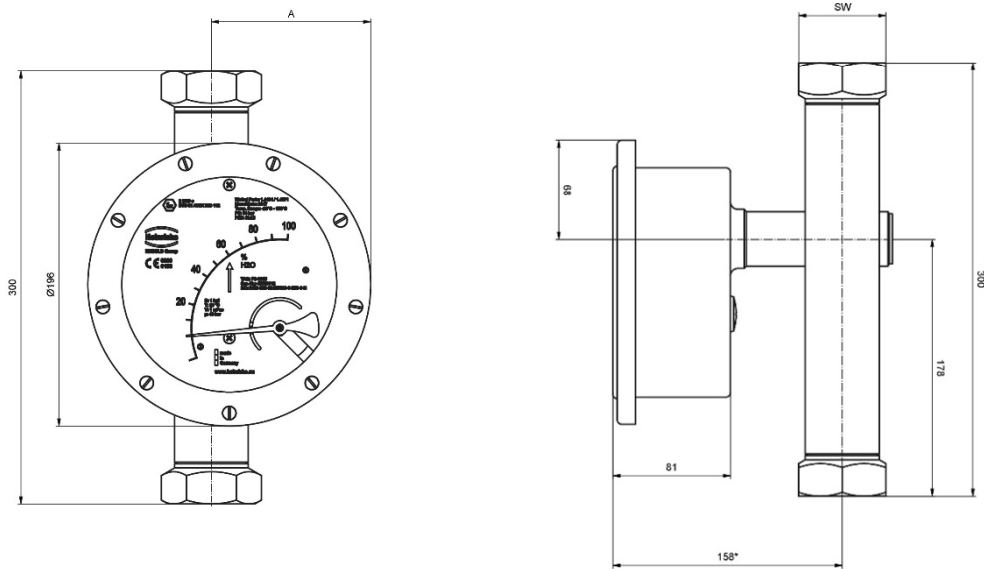

Fitting	NPT(f) / G(f) (in)	PN / CL	SW	Stainless steel Display A (mm)	Aluminum Display A (mm)
S15	1/4; 3/8; 1/2; 3/4	40 / 150/300	36	99,5	77,0
S25	1/4; 3/8; 1/2; 3/4	40 / 150/300	36	102,6	80,1
S40	3/4; 1; 1 1/4	40 / 150/300	60	110,4	87,9
S50	1 1/4; 1 1/2; 2	40 / 150/300	80	123,4	100,9

## Order Code

Example: BGF-S50-321BQPLO-0-S20-0-H

Model code				
BGF				
-	Wetted parts	Process temperature	Process pressure	
S	Stainless steel	max. ≤ 200 °C		
P	PTFE	max. ≤ 125 °C	max. ≤ 16 Bar	
Nominal device size		Measuring range code		
15	Measuring ranges see the measuring range table on page 6	H-L		
25		M-Q		
40		P-S		
50		Q-U		
80		T-W		
Process connection				
For Device size 15	Flange <sup>1)</sup>			
	305B	DN15 PN40 Form B1 DIN EN 1092-1 <sup>3) 6)</sup>	201R 1/2" Class 150 RF ASME B16.5-2003 <sup>5) 8)</sup>	
	3A5B	DN20 PN40 Form B1 DIN EN 1092-1 <sup>3) 6)</sup>	221R 1/2" Class 300 RF ASME B16.5-2003 <sup>5) 8)</sup>	
	309B	DN25 PN40 Form B1 DIN EN 1092-1 <sup>3) 6)</sup>	202R 3/4" Class 150 RF ASME B16.5-2003	
	309D	DN25 PN40 Form D DIN EN 1092-1 <sup>3) 8)</sup>	222R 3/4" Class 300 RF ASME B16.5-2003 <sup>6)</sup>	
	313B	DN32 PN40 Form B1 DIN EN 1092-1 <sup>3) 8)</sup>	203R 1" Class 150 RF ASME B16.5-2003	
	313D	DN32 PN40 Form D DIN EN 1092-1 <sup>3) 8)</sup>	223R 1" Class 300 RF ASME B16.5-2003 <sup>6)</sup>	
			204R 1 1/4" Class 150 RF ASME B16.5-2003 <sup>3)</sup>	
			224R 1 1/4" Class 300 RF ASME B16.5-2003 <sup>6)</sup>	
			406R 15A 10K RF JIS B2220 <sup>8)</sup>	
			407R 15A 16K RF JIS B2220 <sup>8)</sup>	
		Thread <sup>2) 4)</sup>		
	4000	G 1/4" (f)	6010	NPT 1/4" (f)
	4010	G 3/8" (f)	6020	NPT 3/8" (f)
	4020	G 1/2" (f)	6030	NPT 1/2" (f)
4030	G 3/4" (f)	6040	NPT 3/4" (f)	
For Device size 25	Flange <sup>1)</sup>			
	305B	DN15 PN40 Form B1 DIN EN 1092-1 <sup>3) 5) 6)</sup>	202R 3/4" Class 150 RF ASME B16.5-2003 <sup>5) 8)</sup>	
	3A5B	DN20 PN40 Form B1 DIN EN 1092-1 <sup>3) 6)</sup>	222R 3/4" Class 300 RF ASME B16.5-2003 <sup>5) 8)</sup>	
	309B	DN25 PN40 Form B1 DIN EN 1092-1 <sup>3) 6)</sup>	203R 1" Class 150 RF ASME B16.5-2003	
	309D	DN25 PN40 Form D DIN EN 1092-1 <sup>3) 8)</sup>	223R 1" Class 300 RF ASME B16.5-2003 <sup>6)</sup>	
	313B	DN32 PN40 Form B1 DIN EN 1092-1 <sup>3) 6)</sup>	204R 1 1/4" Class 150 RF ASME B16.5-2003	
	313D	DN32 PN40 Form D DIN EN 1092-1 <sup>3) 8)</sup>	224R 1 1/4" Class 300 RF ASME B16.5-2003 <sup>6)</sup>	
			205R 1 1/2" Class 150 RF ASME B16.5-2003	
			225R 1 1/2" Class 300 RF ASME B16.5-2003 <sup>6)</sup>	
			416R 25A 10K RF JIS B2220	
		Thread <sup>2) 4)</sup>		
	4000	G 1/4" (f)	6010	NPT 1/4" (f)
	4010	G 3/8" (f)	6020	NPT 3/8" (f)
	4020	G 1/2" (f)	6030	NPT 1/2" (f)
	4030	G 3/4" (f)	6040	NPT 3/4" (f)
For Device size 40	Flange <sup>1)</sup>			
	317B	DN40 PN40 Form B1 DIN EN 1092-1 <sup>3)</sup>	205R 1 1/2" Class 150 RF ASME B16.5-2003	
	317D	DN40 PN40 Form D DIN EN 1092-1 <sup>3)</sup>	225R 1 1/2" Class 300 RF ASME B16.5-2003	
			426R 40A 10K RF JIS B2220	
			427R 40A 16K RF JIS B2220	
		Thread <sup>2) 4)</sup>		
	4030	G 3/4" (f)	6040	NPT 3/4" (f)
	4040	G 1" (f)	6050	NPT 1" (f)
	4050	G 1 1/4" (f)	6060	NPT 1 1/4" (f)
	For Device size 50	Flange <sup>1), 3)</sup>		
321B		DN50 PN40 Form B1 DIN EN 1092-1 <sup>3) 6)</sup>	206R 2" Class 150 RF ASME B16.5-2003 <sup>3)</sup>	
321D		DN50 PN40 Form D DIN EN 1092-1 <sup>3) 8)</sup>	226R 2" Class 300 RF ASME B16.5-2003 <sup>6)</sup>	
325B		DN65 PN16 Form B1 DIN EN 1092-1 <sup>3) 6)</sup>	207R 2 1/2" Class 150 RF ASME B16.5-2003 <sup>6)</sup>	
325D		DN65 PN16 Form D DIN EN 1092-1 <sup>3) 8)</sup>	227R 2 1/2" Class 300 RF ASME B16.5-2003 <sup>6)</sup>	
326B		DN65 PN40 Form B1 DIN EN 1092-1 <sup>3) 6)</sup>	431R 50A 10K RF JIS B2220 <sup>8)</sup>	
326D		DN65 PN40 Form D DIN EN 1092-1 <sup>3) 8)</sup>	432R 50A 16K RF JIS B2220 <sup>8)</sup>	
		Thread <sup>2) 4)</sup>		
4050		G 1 1/4" (f)	6060	NPT 1 1/4" (f)
4060		G 1 1/2" (f)	6070	NPT 1 1/2" (f)
4070	G 2" (f)	6080	NPT 2" (f)	
For Device size 80	Flange <sup>1)</sup>			
	330B	DN80 PN16 Form B1 DIN EN 1092-1 <sup>3)</sup>	208R 3" Class 150 RF ASME B16.5-2003	
	330D	DN80 PN16 Form D DIN EN 1092-1 <sup>3) 8)</sup>	228R 3" Class 300 RF ASME B16.5-2003 <sup>6)</sup>	
	331B	DN80 PN40 Form B1 DIN EN 1092-1 <sup>3) 6)</sup>	209R 3 1/2" Class 150 RF ASME B16.5-2003	
	331D	DN80 PN40 Form D DIN EN 1092-1 <sup>3) 8)</sup>	229R 3 1/2" Class 300 RF ASME B16.5-2003 <sup>6)</sup>	
			441R 50A 10K RF JIS B2220 <sup>8)</sup>	
		442R 50A 16K RF JIS B2220 <sup>8)</sup>		

Measuring range (Water 20°C, 1mPas) <sup>9)</sup>		
H	10 ... 100 l/h	
I	16 ... 160 l/h	
J	25 ... 250 l/h	
K	40 ... 400 l/h	
L	60 ... 600 l/h	
M	100 ... 1 000 l/h	
N	160 ... 1 600 l/h	
P	250 ... 2 500 l/h	
Q	400 ... 4 000 l/h	
R	600 ... 6 000 l/h	
S	1 000 ... 10 000 l/h	
T	1 600 ... 16 000 l/h	
U	2 500 ... 25 000 l/h	
V	4 000 ... 40 000 l/h	
W	6 000 ... 60 000 l/h	
Magnet bearer		
K	Standard PP bis 80°C (only for device sizes 50 and 80)	
P	PTFE for temperature till 125 °C	
S	Stainless steel	
Flow direction		
O	Top to bottom	
L	Left to right	
R	Right to left	
U	Bottom to top	
Heating / Cooling	Connection for heating/cooling	Wetted materials
0	Without	-
1	With Heating / Cooling	EO12 mm
2	With Heating / Cooling	DN15 PN40 Form B1 DIN EN 1092-1
3	With Heating / Cooling	1/2" Class 150 RF ANSI B16.5-2003
4	With Heating / Cooling	NPT 1/2" (f)
- Certificates		
0	Without	
1	Certificate of compliance with the order 2.1	
2	Certificate of work 2.2	
B	Inspection certificate 3.1 with material analysis (DIN EN 10204:2004)	
C	Inspection certificate 3.2 with material analysis (DIN EN 10204:2004)	
N	Material certificate NACE	
- Display		Process temperature
S	Standard Display part	For electrical output: ≤ 150 °C For local Indication: ≤ 200 °C
V	Standard display part, forward advanced	≤ 200 °C
E	Stainless steel display part	For electrical output: ≤ 150 °C
H	Stainless steel display part, forward advanced	≤ 200 °C
T	Standard display part with pressure compensation	For electrical output: ≤ 150 °C For local Indication: ≤ 200 °C
W	Standard display part with pressure compensation, forward advanced	≤ 200 °C
Scale		
1	% -Scale (Water)	
2	Measuring range-Scale (Water)	
F	Double scale (according to customer Preference)	
4	% -Scale (Media)	
5	Measuring range-Scale (Media)	
Electrical Output		Ambient temperature
0	Without	-40 ... +80 °C
1	1 x inductive switch, Type SJ 3,5 N	-25 ... +80 °C
2	2 x inductive switch, Type SJ 3,5 N	-25 ... +80 °C
3	1 x inductive switch, Type SJ 3,5 SN (safety design)	-40 ... +80 °C <sup>11) 13) 14)</sup>
4	2 x inductive switch, Type SJ 3,5 SN (safety design)	-40 ... +80 °C <sup>11) 13) 14)</sup>
6	Transmitter ES with HART-protocol, 4-20 mA, Ex ia	-40 ... +70 °C <sup>11) 12) 14)</sup>
7	Transmitter ES with HART-protocol, 4-20 mA, Ex ia / 2x NAMUR-switch	-40 ... +70 °C <sup>11) 12) 14)</sup>
8	Transmitter ES with HART-protocol, 4-20 mA, Ex ia / 1x NAMUR-switch, 1x pulse output	-40 ... +70 °C <sup>11) 12) 14)</sup>
L	1 x microswitch	without ATEX -25 ... +70 °C
M	2 x microswitch	without ATEX -25 ... +70 °C
E	1 x inductive switch, Type SB 3,5-E2, three wire	without ATEX -25 ... +70 °C
F	2 x inductive switch, Type SB 3,5-E2, three wire	without ATEX -25 ... +70 °C
G	1 x inductive switch, Type NCB2-12GM40-Z0	without ATEX -25 ... +70 °C
K	elektr. Messwertumformer ES mit Foundation Fieldbus	-40 ... +70 °C
- Accessories		
0	Without	
S	SIL Conformity assessment by EXIDA	
X	Customised, on customer request	
- Design		
H	Heinrichs	
K	Kobold	

References:

- 1) Installation length 250mm.
- 2) Installation length 300mm
- 3) Flanges in older DIN standard on request
- 4) Float not removable
- 5) Reduced sealing strip.
- 6) Pressure stage for model "S".
- 7) only possible with an advanced display section
- 8) Not for model "P"
- 9) Conversion is not possible taking into account the viscosity
- 10) Combination stainless steel display part with ES and counter module not possible
- 11) SIL 1 - IEC 61508-2:2010 Conformity confirmed by EXIDA.
- 12) SIL 1 - IEC 61508-2:2000 Conformity confirmed by EXIDA.
- 13) SIL 2 - IEC 61508-2:2000 Conformity confirmed by EXIDA.
- 14) SIL conformity only with "Accessories" option "S"
- 15) Only in combination with "electrical output" for options "3", "4", "6", "7", "8"