



# Resistance Thermometers

## Ignition Protection Exd



measuring  
•  
monitoring  
•  
analysing

### TWL-Exd



Fieldbus  
Foundation



- Measuring range: -198 ... +600 °C
- Pt100 sensor: class F0.3 (B), class F0.15 (A), F0.1 (1/3 DIN), F0.03 (1/10 DIN) or cryogenic
- Output: Resistance or analogue 4-20 mA
- Thermowells up to 1000, 3000 respectively 5000 mm (depending on model)
- Option: Headtransmitter with HART®-protocol or PROFIBUS®/Fieldbus, display
- For ATEX applications, ignition protection Exd



T2

KOBOLD companies worldwide:

ARGENTINA, AUSTRALIA, AUSTRIA, BELGIUM, BULGARIA, CANADA, CHILE, CHINA, COLOMBIA, CZECHIA, EGYPT, FRANCE, GERMANY, GREAT BRITAIN, HUNGARY, INDIA, INDONESIA, ITALY, MALAYSIA, MEXICO, NETHERLANDS, PERU, POLAND, REPUBLIC OF KOREA, ROMANIA, SINGAPORE, SPAIN, SWITZERLAND, TAIWAN, THAILAND, TUNISIA, TURKEY, USA, VIETNAM

KOBOLD Messring GmbH  
Nordring 22-24  
D-65719 Hofheim/Ts.  
Head Office:  
+49(0)6192 299-0  
+49(0)6192 23398  
info.de@kobold.com  
www.kobold.com



### Description

The KOBOLD resistance thermometers comprise a rugged installation fitting made of stainless steel with thread, flange or weld-on connection, a connection head out of aluminium casting and a removable measuring element. The measuring insert can be replaced without emptying the installation, since the customised thermowell remains in the installation and seals the process. The instruments are supplied with the ignition protection Exd as a standard and therefore can be installed in relevant hazardous areas.

A Pt100 temperature sensor according to IEC60751, class F0.15 (A), F0.1 (1/3 DIN), F0.03 (1/10 DIN) or cryogenic is fitted in the measuring insert as standard. Depending on customer request the temperature sensor can be carried out as 2-, 3- or 4-wire circuit.

Alternatively these sensors can be designed as single or double resistance thermometers. Exceptional the 4-wire version, which can only be build with one Pt100 due to lack of space.

As an option the resistance thermometers can be supplied with a head transmitter. Transmitter with a standard 4-20 mA signal, with HART® protocol or with PROFIBUS®/Fieldbus® are there to choose from.

Beside the available resistance thermometers according to DIN-standard, there are customised versions relating to the immersion length, the connection head, the materials, the process connection or the tolerance classes deliverable on request.

### Head Transmitter

Resistance thermometers with head transmitter are used whenever a measuring signal must be transported long distance without any disturbance.

The head transmitter which is encapsulated in epoxide resin is located right in the connection head and delivers a temperature-linear output signal of 4-20 mA. The head transmitter is available with standardised communication systems just like HART® protocol or PROFIBUS®/Fieldbus®.

### Applications

The resistance thermometers with thread-, flange- or weld-on connection are favourably used for the temperature measurement in liquids, solids and gaseous media. The reliable watertightness of these installation methods for gauge pressure and vacuum is an important criteria for selection.

Application areas are located in the air-conditioning and cooling industry, the heating-, furnace-, mechanical- and apparatus-construction as well as in the complete industry.

For all applications in hazardous areas, the instruments are supplied with the ignition protection Exd.

### Technical Details

Meas. principle:	Temperature depending resistor
Meas. range:	-70 ... +250 °C -70 ... +400 °C -70 ... +600 °C -198 ... +100 °C
Sensor:	Pt 100 single- or double-sensor (1 x Pt100 or 2 x Pt100)
Accuracy:	Class F0.15 (A), F0.1 (1/3 DIN), F0.03 (1/10 DIN) or cryogenic
Ambient temperature:	-40 ... +150 °C with ceramic terminal base (without transmitter) -40 ... +85 °C (with transmitter) -20 ... +70 °C (with LCD display) -20 ... +80 °C (with LED display)
Operating pressure:	Up to 250 bar (depending on thermowell) TWL-1: pressureless TWL-3 and sensors without thermowell atmospheric pressure
Connection head:	Form XD with chain (no chain with optional display)
Cable entry:	M 20 x 1.5 standard (others on request)
Materials:	
- Sensor:	Stainless steel 1.4404
- Thermowell:	Stainless steel 1.4404 (others on request)
- Neckpipe:	Stainless steel 1.4404
- Connection head:	Aluminium, painted
- Terminal base:	Ceramic (without transmitter)
Process connection:	
- Thread:	G 1/2 male, G 3/4 male, G1 male, 1/2" NPT, 3/4" NPT, 1" NPT
- DIN-flange:	DN 15, 20, 25, 32, 40, 50
- ANSI flange:	1/2", 3/4", 1", 1 1/2", 2"
- Weld-in:	3/4", 1", 1 1/4"
Sensor wiring:	2-, 3- or 4-wire
Output:	Resistance value
Protection:	Connection head IP 54...68 depending on cable gland and sealing sensor IP 68



**Technical Details** (continued)

ATEX-approval: II 2 GD Ex d IIC T6

Head transmitter:

- Output: Analogue output 4-20 mA

- Communication: HART®-protocol, PROFIBUS®/Fieldbus

- Minimum meas. span: Standard transmitter 25 °K  
transmitter with HART® 10 °K  
transmitter with PROFIBUS®/Fieldbus 5 °K

- Supply voltage: 8-35 V<sub>DC</sub> for standard transmitter and transmitter with HART®  
9-32 V<sub>DC</sub> for transmitter with PROFIBUS®/Fieldbus

Display:

- Type: 4 digit LCD or LED

- Supply: loop powered

- Voltage drop out: LCD max. 2.5 V  
LED 3.3 V at 4 mA  
3.7 V at 20 mA



**Order Details** (example: TWL-1 1 2 L N D N 5 C A 1)

Model	Sensor specification				
	Type	Sensor type / class	Sensor wiring	Connection head / transmitter	Process connection of sensor
TWL-	0 = without	0 = without	0 = without	0 = without (for TWL-0/3)	N <sup>2)</sup> = 1/2" NPT male G = G 1/2 male X = special
	1 = standard 2 = with nipple union 4 = Compression Fitting	A = 1 x Pt100 class B (-70 ... +250 °C) B = 2 x Pt100 class B (-70 ... +250 °C) C = 1 x Pt100 class A (-70 ... +250 °C) D = 2 x Pt100 class A (-70 ... +250 °C) E = 1 x Pt100 class B (-70 ... +400 °C) F = 2 x Pt100 class B (-70 ... +400 °C) G = 1 x Pt100 class A (-70 ... +400 °C) H = 2 x Pt100 class A (-70 ... +400 °C) I = 1 x Pt100 class B (-70 ... +600 °C) J = 2 x Pt100 class B (-70 ... +600 °C) K = 1 x Pt100 class A (-70 ... +600 °C) L = 2 x Pt100 class A (-70 ... +600 °C) M = 1 x Pt100 class 1/8 DIN (-70 ... +250 °C) N = 1 x Pt100 class 1/10 DIN (-70 ... +250 °C) O = 1 x Pt100 class 1/8 DIN (-70 ... +400 °C) P = 1 x Pt100 class 1/10 DIN (-70 ... +400 °C) Q = 1 x Pt100 class cryogenic (-198 ... +100 °C) X = special options	2 = 2-wire 3 = 3-wire 4 <sup>1)</sup> = 4-wire	L <sup>6)</sup> = ATEX Exd / without transmitter A <sup>7)6)</sup> = ATEX Exd / programmable 2-wire transmitter (model: 5333D) B <sup>7)6)</sup> = ATEX Exd / programmable 2-wire transmitter with HART® protocol (model: 5337D) C <sup>6)7)</sup> = ATEX Exd / transmitter with PROFIBUS® / Fieldbus® (model: 5350A) X = special option (specify in clear text)  for options A, B, C choose sensor wiring code "3"	
	3 = measuring insert				

<sup>1)</sup> 4-wire only for 1 sensor    <sup>2)</sup> Choose "N" for TWL-2    <sup>3)</sup> Display only available for 4...20 mA or Hart® transmitters. Choose transmitter code A or B  
<sup>7)</sup> Please specify the measuring range in clear text while ordering    <sup>8)</sup> Separate programming kit needed



Order Details (continued)

Thermowell specification				Length (sensor, thermowell, measuring insert) <sup>4)</sup> (see drawings)	Options
Thermowell type	Process connection	Process connection size	Nominal pressure (process connection)		
<b>0</b> = without <b>B</b> = cylindrical, multipart, welded <b>G</b> = cylindrical, bar stock/drilled with stepped shank <b>D</b> = tapered shank, bar stock/drilled <b>F</b> = cylindrical, bar stock/drilled <b>X</b> = special option	<b>0</b> = without (for TWL-3)	<b>0</b> = without (for TWL-3)	<b>0</b> = without (for TWL-3)	<b>only for TWL-0</b> (only thermowell) <b>0</b> = without lagging extension "T" <b>1</b> = with lagging extension "T"  <b>sensor with thermowells</b> (only for TWL-1/TWL-2) <b>A</b> = with standard neckpipe "HL"/ without lagging extension "T" <b>B</b> = with standard neckpipe "HL" and with lagging ext. "T" <b>C</b> <sup>5)</sup> = without neckpipe "HL"/ with lagging extension "T" <b>D</b> <sup>5)</sup> = without neckpipe "HL"/ without lagging extension "T" <b>E</b> = with special neckpipe length "HL"/ with lagging ext. "T" <b>F</b> = with special neckpipe length "HL"/ without lagging ext. "T"  <b>sensor without thermowells</b> (only for TWL-1/TWL-2) <b>G</b> = with standard neckpipe length "HL" <b>H</b> = with special neckpipe length "HL" <b>J</b> = without neckpipe "HL" <b>X</b> = special option (specify in clear text) <b>M</b> = measuring insert (only for TWL-3, specify length "ML")	<b>0</b> = without <b>1</b> <sup>6)</sup> = with LCD display <b>2</b> <sup>6)</sup> = with LED display <b>Y</b> = special option (specify in clear text)
	<b>G</b> = G-thread <b>N</b> = NPT-thread <b>X</b> = Special	<b>4</b> = ½" <b>5</b> = ¾" <b>6</b> = 1" <b>X</b> = special	<b>A</b> = PN 25 (only for thermowell B) <b>B</b> = PN 100 (only for thermowell G) <b>C</b> = PN 250 (only for thermowell D/F)		
	<b>B</b> <sup>7)</sup> = BW Butt Welding <b>S</b> <sup>9)</sup> = SW Socket Welding	<b>5</b> = ¾", only for thermowell G <b>6</b> = 1" <b>7</b> = 1 ¼", only for thermowell D <b>8</b> = 1-½" <b>X</b> = special	<b>B</b> = PN 100 (only for thermowell G) <b>C</b> = PN 250 (only for thermowell D/F)		
	<b>F</b> = EN1092-1 flange	<b>4</b> = DN 15 <b>5</b> = DN 20 <b>6</b> = DN 25 <b>7</b> = DN 32 <b>8</b> = DN 40 <b>9</b> = DN 50 <b>X</b> = special	<b>1</b> = PN63 (not for DN 15) <b>2</b> = PN10/16 <b>3</b> = PN40 <b>4</b> = PN100 (not for DN 15) <b>X</b> = special		
	<b>A</b> = ASME B16.5 flange	<b>4</b> = ½" (not for thermowell G/D) <b>5</b> = ¾" <b>6</b> = 1" <b>8</b> = 1 ½" <b>9</b> = 2" <b>X</b> = special	<b>5</b> = 150 lbs <b>6</b> = 300 lbs <b>7</b> = 600 lbs (not for ½") <b>8</b> = 900 lbs (not for ½") <b>9</b> = 1500 lbs (not for ½") <b>X</b> = special		

<sup>3)</sup> Not for thermowell type B, F, G

<sup>4)</sup> Immersion length "U" and hole diameter "i" (when ordering thermowell only) or "EL" (when ordering without thermowell), neckpipe length "HL" (when different from stdd. i.e. for TWL-1 stdd. is 130 mm, for TWL-2 standard is 150 mm), lagging extension "T" (if ordered) and measuring insert length "ML" (when ordering TWL-3) must be specified in clear text when ordering.

Pls. check lengths very precisely in order to ensure a perfect match between sensor and thermowell.

<sup>5)</sup> Not for TWL-2

<sup>6)</sup> Display only available for 4 ... 20 mA or Hart® transmitters. Choose transmitter code A or B

<sup>7)</sup> Not for thermowell model B, D

**Note:** Nominal pressure for TWL-3 and sensors without thermowell is atmospheric pressure.



**Order Details for Ordering only the Thermowell** (example: **TWL-0000NBG4000**)

Model	Sensor type	Sensor type/class	Sensor Wiring	Connection head/ transmitter	Process connection of temperature sensor <sup>1)</sup>
TWL-	0 = without	0 = without	0 = without	0 = without	N <sup>1)</sup> = 1/2" NPT male G = G 1/2 male X = special

<sup>1)</sup> choose N for nipple and union version

**Order Details for Ordering only the Thermowell** (continued)

Thermowell specification				Immersion length and lagging extension length <sup>1)</sup>	Special option
Thermowell type	Process connection size	Nominal pressure (process connection)	Pressure rating for flange connection		
Please use the specification codes according to order table shown on page 4				0 = without lagging extension "T" 1 = with lagging extension "T"	0 = without Y = option acc. specification

<sup>1)</sup> Immersion length "U", hole diameter "i" and lagging extension "T" must be specified in writing. Please check lengths very precise in order to ensure a perfect match of sensor and thermowell.

**Dimensions Temperature Sensor TWL-1**  
Illustration without thermowell\*

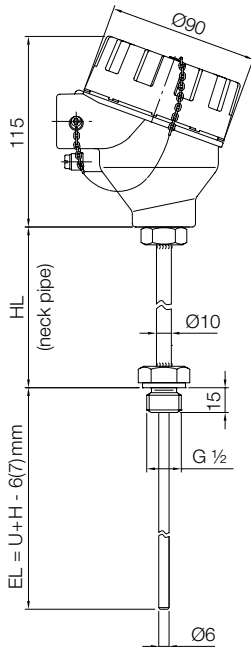

**HL** = neckpipe length  
standard 130 mm for TWL-1  
standard 150 mm for TWL-2

**EL** = immersion length

**EL** = U+H-7 mm for thermowell type B  
U+H-8 mm for thermowell type G/D

**Dimensions Temperature Sensor TWL-2**  
Illustration without thermowell\*

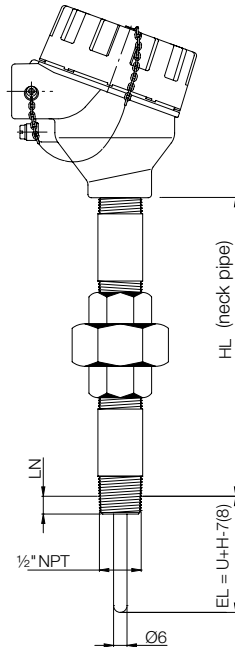

**U** = immersion length thermowell (see drawing thermowell)

**H** = length see thermowell

**LN** = screw-in-length by hand (approx. 8.1 mm at 1/2" NPT)

**Dimensions Temperature Sensor TWL-4**  
Illustration without thermowell\*

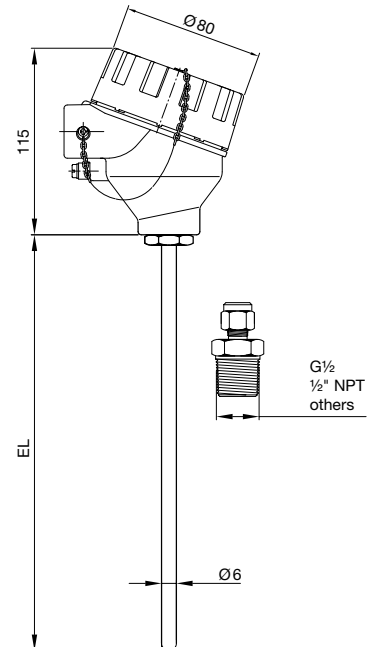

\* For Ex-applications an adequate thermowell is needed

**Dimensions Measuring Insert TWL-3**

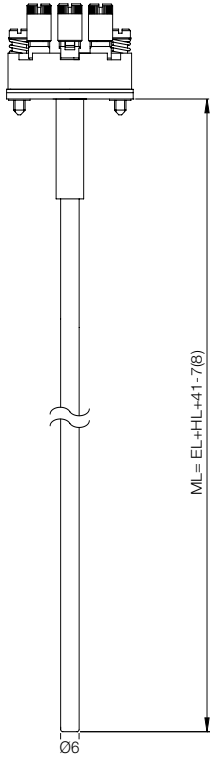

**HL** = neckpipe length  
**EL** = immersion length  
**ML** = measuring insert length

**Dimensions Connection Head with Display**

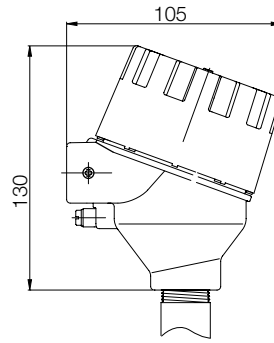

**Lagging Extension »T«**

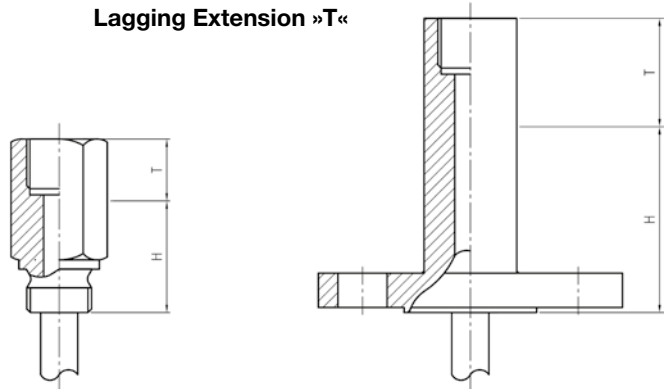

**Dimensions Thermowell Model TWL- ... B ...**

Cylindrical thermowell, welded, with process connection G-thread (max. PN25 at 20 °C)

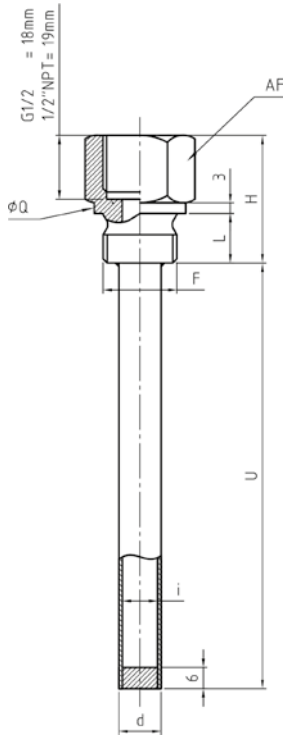

**Lagging Extension "T"**

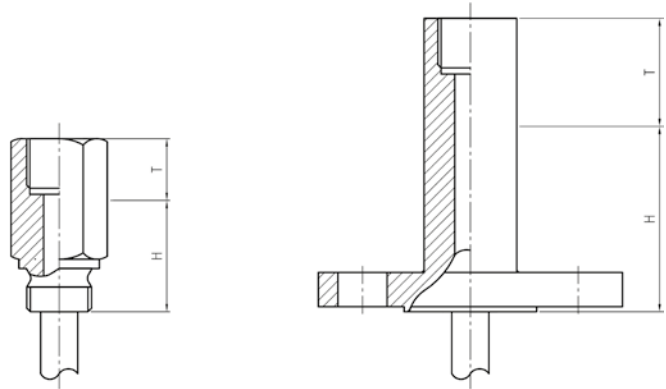

Process connection	Max. total length	AF	F	i	d	H	L	Q
G-thread	5000 mm	27	G 1/2	10	12	36	14	26
				12	14			
		36	G 3/4	10	12	38	16	31.7
				12	14			
		41	G 1	10	12	40	18	39
				12	14			

**Dimensions Thermowell Model TWL- ... B ...**

Cylindrical thermowell, welded, with process connection NPT-thread (max. PN25 at 20 °C)

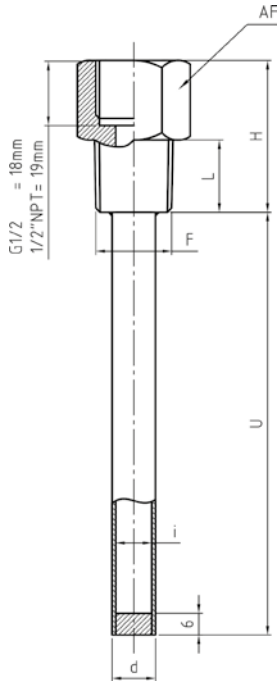

Process connection	Max. total length	AF	F	i	d	H	L
NPT-thread	5000 mm	27	½" NPT	10	12	42	20
				12	14		
		27	¾" NPT	10	12	43	20
				12	14		
		36	1" NPT	10	12	46	24
				12	14		

**Dimensions Thermowell Model TWL- ....B ...**

Cylindrical thermowell, welded, with process connection flange acc. EN-1092 or ASME (max. PN10...40 at 20 °C)

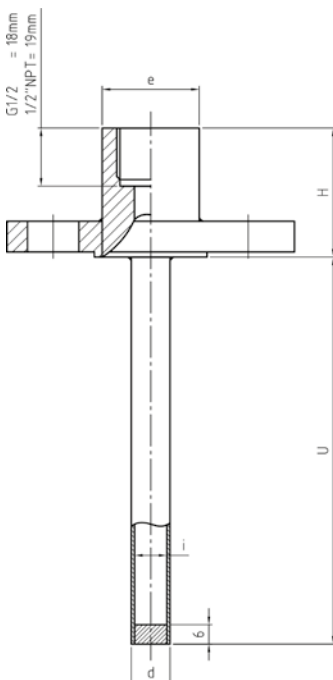

Process connection		Max. total length	i	d	H	e
with flange	ASME B16.5 ½"	5000 mm	10/12	12/14	40	30
	ASME B16.5 ¾"					
	ASME B16.5 1"					
	ASME B16.5 1 ½"					
	ASME B16.5 2"					
	EN1092-1 DN 15		10/12	12/14	40	30
	EN1092-1 DN 20					
	EN1092-1 DN 25					
	EN1092-1 DN 32					
	EN1092-1 DN 40					
EN1092-1 DN 50				35		



**Dimensions Thermowell Model TWL-...G...**

Cylindrical thermowell, bar stock/drilled with stepped shank and process connection G-thread (max. PN 100 at 20°C)

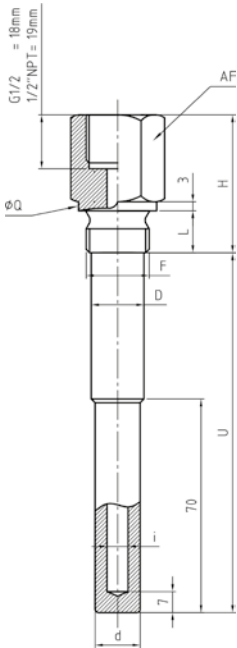

Process connection	Max. total length	AF	F	i	d	D	H	L	Q
G-thread	1000 mm	27	G 1/2	7-8-9	15	17	46	14	26
				10-12	17	17			
		36	G 3/4	7-8-9	15	18		16	31.7
				10-12	18	21			
		41	G 1	7-8-9	15	21	18	39	
				10-12	18	25			51

**Dimensions Thermowell Model TWL-...G...**

Cylindrical thermowell, bar stock/drilled with stepped shank and process connection NPT-thread (max. PN 100 at 20°C)

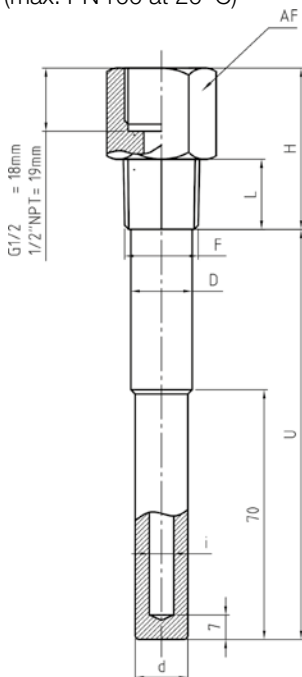

Process connection	Max. total length	AF	F	i	d	D	H	L
NPT-thread	1000 mm	27	1/2" NPT	7-8-9	15	17	46	20
				10-12	17	17		
		27	3/4" NPT	7-8-9	15	18		24
				10-12	18	21		
		36	1" NPT	7-8-9	15	21	51	
				10-12	18	25		

**Dimensions Thermowell Model TWL-...G...**

Cylindrical thermowell, bar stock/drilled with stepped shank and process connection flange acc. EN-1092 or ASME (max. PN 100 at 20 °C)

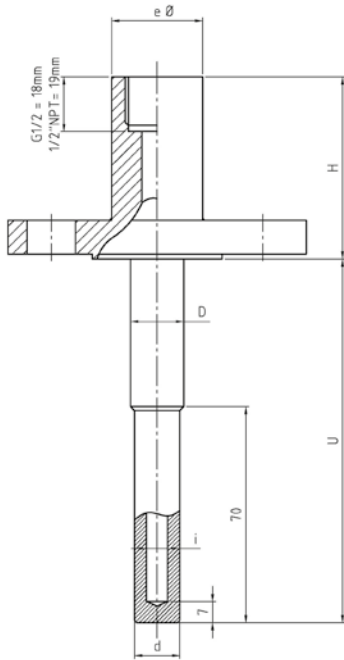

Process connection		Max. total length	i	d	D	H	e				
Flange	ASME B16.5 ¾"	1000 mm	7-8-9	15	17.5	60	30				
			10-12	17.5	17.5						
	ASME B16.5 1"		7-8-9	15	18			60	35		
			10-12	18	21						
	ASME B16.5 1½"		7-8-9	15	21					60	30
			10-12	18	25						
	ASME B16.5 2"		7-8-9	15	21	60	30				
			10-12	18	25						
	EN1092-1 DN 15		7	12	15			60	30		
	EN1092-1 DN 20		7-8-9	15	17.5						
			10-12	17.5	17.5						
	EN1092-1 DN 25		7-8-9	15	18					60	35
			10-12	18	21						
	EN1092-1 DN 32		7-8-9	15	21	60	35				
			10-12	18	25						
	EN1092-1 DN 40		7-8-9	15	21			60	35		
			10-12	18	25						
	EN1092-1 DN 50		7-8-9	15	21					60	35
10-12		18	25								

**Dimensions Thermowell Model TWL-...G...**

Cylindrical thermowell, bar stock/drilled with stepped shank and process connection for weld-on (max. PN 100 at 20 °C)

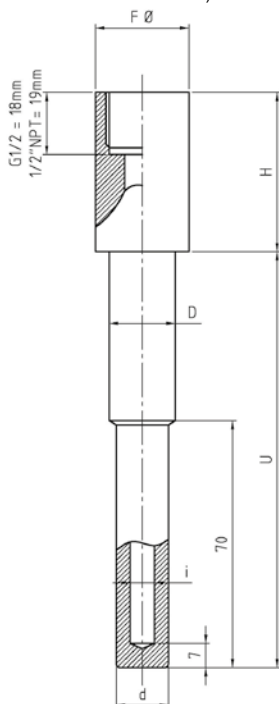

Process connection		Max. total length	F	i	d	D	H
Socket Welding (SW)	¾"	1000 mm	26.6	7-8-9	15	19	46
				10-12	18		
	1"		33.4	7-8-9	15	22	51
				10-12	18		
	1¼"		42.16	7-8-9	15	29	60
				10-12	18		
	1½"		48.26	7-8-9	15	35	60
				10-12	18		

**Dimensions Thermowell Model TWL-...D...**

Tapered shank, bar stock/drilled thermowell with process connection G-thread (max. PN250 at 20 °C)

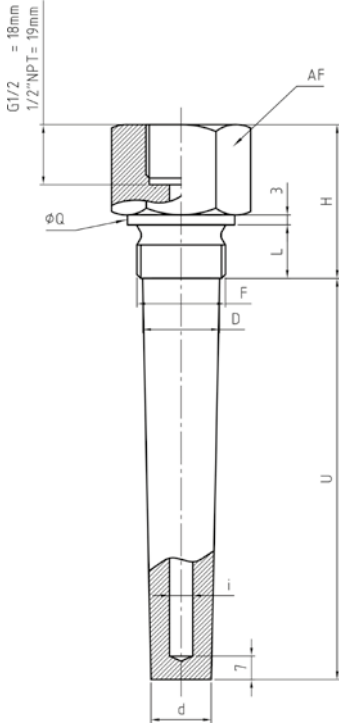

Process connection	Max. total length	AF	F	I	d	D	H	L	Q
G-thread	1000 mm	27	G 1/2"	7-8-9	15	17	46	14	26.6
		36	G 3/4"	7-8-9	18	23	46	20	31.7
				10-12	21				
		41	G 1"	7-8-9	18	29	51	25	39
				10-12	21				

**Dimensions Thermowell Model TWL-...D...**

Tapered shank, bar stock/drilled thermowell with process connection NPT-thread (max. PN250 at 20 °C)

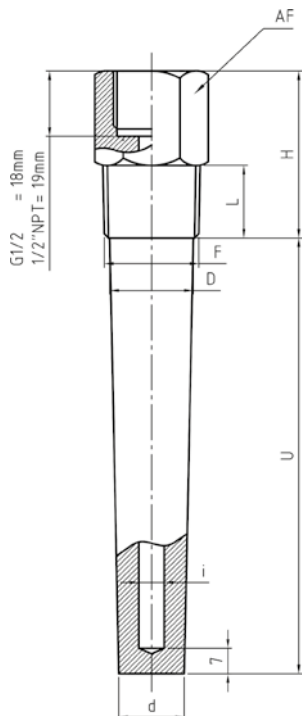

Process connection	Max. total length	AF	F	I	d	D	H	L
NPT-thread	1000 mm	27	1/2" NPT	7-8-9	15	17	46	20
		27	3/4" NPT	7-8-9	18	23	46	20
				10-12	21			
		36	1" NPT	7-8-9	18	29	51	24
				10-12	21			

**Dimensions Thermowell Model TWL-...D...**

Tapered shank, bar stock/drilled thermowell with process connection flange acc. EN-1092 or ASME (max. PN250 at 20°C)

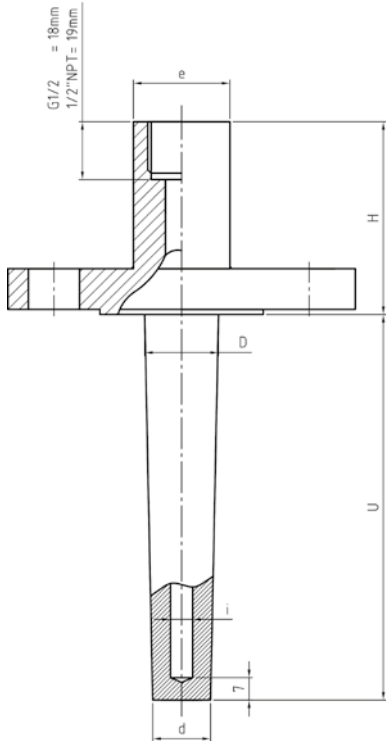

Process connection		Max. total length	i	d	D	H	e
flange	ASME 3/4"	1000 mm	7	15	17.5	60	30
	ASME 1"		7-8-9	18	23	60	30
			10-12	21			
	ASME 1 1/2"		7-8-9	18	29	60	35
			10-12	21			
	ASME 2"		7-8-9	18	29	60	35
			10-12	21			
	EN1092-1 DN 20		7-8-9	15	17.5	60	30
	EN1092-1 DN 25		7-8-9	18	23	60	30
			10-12	21			
EN1092-1 DN 32	7-8-9	18	29	60	35		
10-12	21						
EN1092-1 DN 40	7-8-9	18	29	60	35		
10-12	21						
EN1092-1 DN 50	7-8-9	18	29	60	35		
10-12	21						

**Dimensions Thermowell Model TWL-...D...**

Tapered shank, bar stock/drilled thermowell with process connection for weld-on (max. PN250 at 20°C)

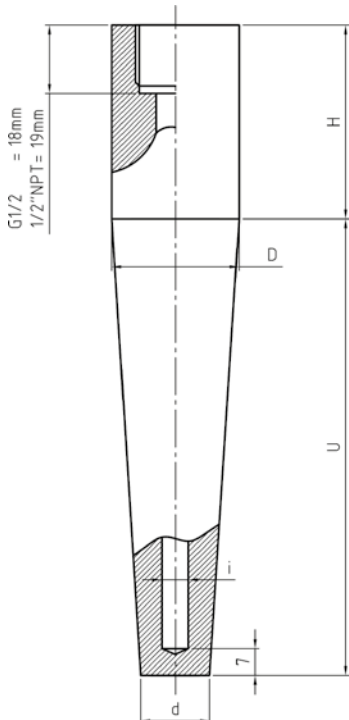

Process connection		Max. total length	l	d	D	H
Butt Welding (BW)	1"	1000 mm	7-8-9	18	25.4	51
			10-12	21		
	1 1/4"		7-8-9	18	31.7	60
			10-12	21		
	1 1/2"		7-8-9	19.5	38.1	60
			10-12	25.4		

**Dimensions Thermowell Model TWL-...F...**

Cylindrical thermowell, bar stock/drilled and process connection G-thread  
(max. PN250 at 20°C)

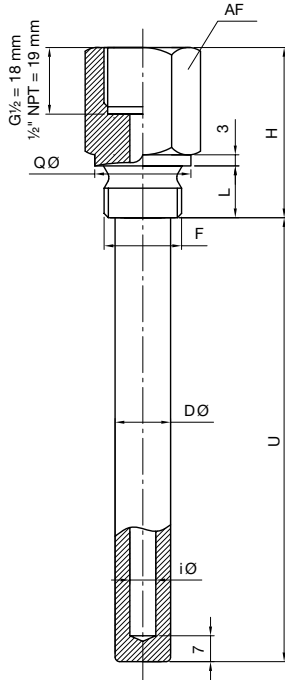

Process connection	Max. total length	AF	F	I	D	H	L	Q
G thread	1000 mm	27	G 1/2"	7-8-9	17	46	14	26,6
		36	G 3/4"	7-8-9	23	46	20	31,7
				10-12				
41	G 1"	7-8-9	29	51	25	39		
		10-12						

**Dimensions Thermowell Model TWL-...F...**

Cylindrical thermowell, bar stock/drilled and process connection NPT-thread  
(max. PN250 at 20°C)

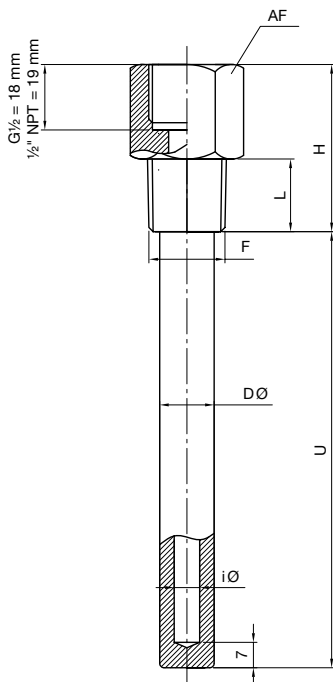

Process connection	Max. total length	AF	F	I	D	H	L
NPT thread	1000 mm	27	1/2" NPT	7-8-9	17	46	20
		27	3/4" NPT	7-8-9	23	46	20
				10-12			
36	1" NPT	7-8-9	29	51	24		
		10-12					

**Dimensions Thermowell Model TWL-...F...**

Cylindrical thermowell, bar stock/drilled and process connection flange acc. DIN or ANSI  
(max. PN 100 at 20 °C)

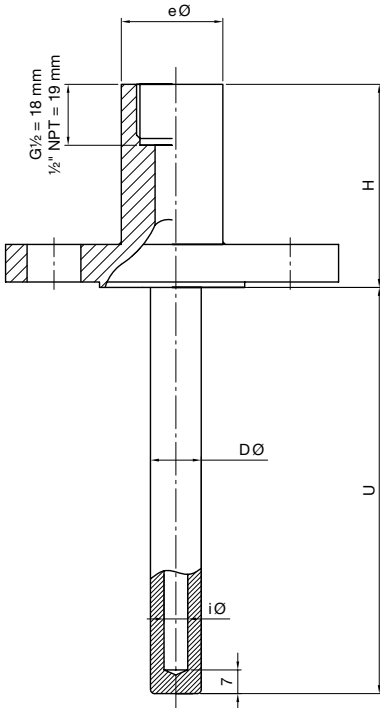

Process connection		Max. total length	I	D	H	e
Flange	ANSI B16.5 3/4"	1000 mm	7-8-9	17.5	60	30
			10-12	17.5		
	7-8-9		18			
	10-12		21			
	7-8-9		21			
	10-12		25			
	7-8-9		21	60	35	
	10-12		25			
	7-8-9		17.5			
	10-12		17.5			
	7-8-9		18			
	10-12		21			
	EN1092-1 DN 20		7-8-9	21	60	30
	EN1092-1 DN 25		10-12	17.5		
7-8-9		18				
EN1092-1 DN 32	10-12	21				
	7-8-9	21				
EN1092-1 DN 40	10-12	25				
	7-8-9	21				
EN1092-1 DN 50	10-12	25	60	35		
	7-8-9	21				
			10-12	25		

**Dimensions Thermowell Model TWL-...F...**

Cylindrical thermowell, bar stock/drilled and process connection for weld-on  
(max. PN 250 at 20 °C)

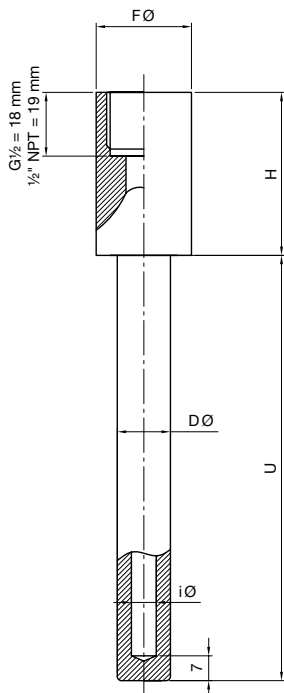

Process connection		Max. total length	I	F	D	H
Socket Welding (SW)	1"	1000 mm	7-8-9	33.4	22	51
			10-12			
	1 1/4"		7-8-9	42.16	29	60
			10-12			
	1 1/2"		7-8-9	48.26	35	60
			10-12			